

DAN-F10N

Standard precision GNSS antenna module
Professional grade

Data sheet

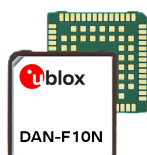

Abstract

This data sheet describes the DAN-F10N antenna module, an L1/L5 dual-band GNSS receiver for meter-level accuracy in urban environment and a simple design-in requiring no RF expertise.

Note! GPS L5 signals are pre-operational and not used by default. Refer to the Overview section for more information.

www.u-blox.com

UBXDOC-963802114-13074 - R02
C1-Public



Document information

Title	DAN-F10N	
Subtitle	Standard precision GNSS antenna module	
Document type	Data sheet	
Document number	UBXDOC-963802114-13074	
Revision and date	R02	06-Mar-2025
Disclosure restriction	C1-Public	

Product status	Corresponding content status	
Functional sample	Draft	For functional testing. Revised and supplementary data will be published later.
In development / prototype	Objective specification	Target values. Revised and supplementary data will be published later.
Engineering sample	Advance information	Data based on early testing. Revised and supplementary data will be published later.
Initial production	Early production information	Data from product verification. Revised and supplementary data may be published later.
Mass production / End of life	Production information	Document contains the final product specification.

This document applies to the following products:

Product name	Type number	FW version	IN/PCN reference	Product status
DAN-F10N	DAN-F10N-00B-00	EXT SPG 6.00	N/A	Prototype

u-blox or third parties may hold intellectual property rights in the products, names, logos and designs included in this document. Copying, reproduction, or modification of this document or any part thereof is only permitted with the express written permission of u-blox. Disclosure to third parties is permitted for clearly public documents only.

The information contained herein is provided "as is" and u-blox assumes no liability for its use. No warranty, either express or implied, is given, including but not limited to, with respect to the accuracy, correctness, reliability and fitness for a particular purpose of the information. This document may be revised by u-blox at any time without notice. For the most recent documents and product statuses, visit www.u-blox.com.

Copyright © 2025, u-blox AG.

Contents

1 Functional description.....	4
1.1 Overview.....	4
1.2 Performance.....	4
1.3 Supported GNSS constellations.....	5
1.4 Supported protocols.....	6
1.5 Firmware features.....	6
1.6 Integrated antenna.....	7
2 Block diagram.....	9
3 Pin definition.....	10
3.1 Pin assignment.....	10
4 Electrical specifications.....	13
4.1 Absolute maximum ratings.....	13
4.2 Operating conditions.....	13
4.3 Indicative power requirements.....	14
5 Communication interfaces.....	16
5.1 UART.....	16
5.2 Default interface settings.....	16
6 Mechanical specifications.....	17
7 Qualifications and approvals.....	18
8 Product handling.....	19
8.1 Packaging.....	19
8.1.1 Reels.....	19
8.2 Soldering.....	19
9 Product marking and ordering information.....	20
9.1 Product marking.....	20
9.2 Product identifiers.....	20
9.3 Ordering codes.....	21
Related documents.....	22
Revision history.....	23

1 Functional description

1.1 Overview

The DAN-F10N patch-antenna module is built on the u-blox F10 dual-band GNSS technology using the L1 and L5 band signals. The proprietary dual-band multipath mitigation technology enables the u-blox F10 to use the best signals from the L1 and L5 bands providing a solid meter-level position accuracy in urban environment.

The compact 20 x 20 x 8 mm patch antenna provides the optimal balance between the size and the performance of a Right Hand Circular Polarized (RHCP) L1/L5 dual-band antenna. The wide beamwidth of the patch antenna enhances flexibility for device installation and the option to use an external antenna further increases design flexibility.

The DAN-F10N module's robust SAW-LNA-SAW RF architecture and the additional notch filter (LTE B13) on L1 RF path ensure the best possible out-of-band interference mitigation. It is well suited for designs with a nearby cellular modem.

The future-proof DAN-F10N includes internal flash to enable firmware upgradability. It also supports antenna switch function and can optionally be connected to an external dual-band GNSS antenna. DAN-F10N is designed as a surface mount device, allowing for an automated manufacturing.

Incorporating the DAN-F10N dual-band antenna module into customer designs is easy and straightforward, thanks to the embedded antenna module, robust RF design, simple interface, and sophisticated interference suppression that ensures maximum performance even in GNSS-hostile environments.

- ⚠ At the time of writing, the GPS L5 signals remain pre-operational and are set as unhealthy until sufficient monitoring capability is established. This is an operational issue concerning the satellites / space segment and not a limitation of u-blox products.
- ⚠ Due to the pre-operational status, the GPS L5 signals are not used for the navigation solution by default. However, it is possible to evaluate the GPS L5 signals before they become fully operational by changing the receiver configuration to override the GPS L5 health status. Refer to the Integration manual [1] for details.

1.2 Performance

Parameter	Specification	Value
Receiver type		u-blox F10 dual-band receiver
Accuracy of time pulse signal	RMS	30 ns
	99%	60 ns
Frequency of time pulse signal		Default 1PPS (0.25 Hz to 10 MHz configurable)
Operational limits ¹	Dynamics	≤ 4 g
	Altitude	80,000 m
	Velocity	500 m/s
Velocity accuracy ²		0.05 m/s
Dynamic heading accuracy ²		0.3 deg

Table 1: DAN-F10N specifications

¹ Assuming Airborne 4 g platform.

² 50% at 30 m/s for dynamic operation.

Table 2 shows typical performance values with the internal antenna in multi-GNSS configurations³. SBAS is enabled in all measurements.

Parameter		GPS+GAL +BDS (Default)	GPS+BDS	GPS+GAL	GPS+NavIC	Unit
Max navigation update rate ⁴		10	10	10	10	Hz
Position accuracy (CEP) ⁵		1	1	1	1	m
Time To First Fix (TTFF) ⁶	Cold start	28	28	27	27	s
	Hot start	2	2	2	2	s
	AssistNow Online ⁷	2	2	2	2	s
	AssistNow Offline ⁸	3	3	3	3	s
	AssistNow Autonomous ⁹	4	4	4	4	s
Sensitivity ¹⁰	Tracking and navigation	-164	-164	-164	-164	dBm
	Reacquisition	-156	-156	-156	-156	dBm
	Cold Start	-145	-145	-145	-145	dBm
	Hot start	-156	-156	-156	-156	dBm

Table 2: DAN-F10N typical performance in multi-GNSS configurations

Table 3 shows typical performance values with the internal antenna in single-GNSS configurations³. SBAS is enabled in all measurements.

Parameter		GPS	BDS	Unit
Max navigation update rate ⁴		20	20	Hz
Position accuracy (CEP) ⁵		1.5	1	m
Time To First Fix (TTFF) ⁶	Cold start	27	42	s
	Hot start	2	2	s
	AssistNow Online ⁷	2	N/A	s
Sensitivity ¹⁰	Tracking and navigation	-164	-160	dBm
	Reacquisition	-156	-153	dBm
	Cold Start	-145	-134	dBm
	Hot start	-156	-154	dBm

Table 3: DAN-F10N typical performance in single-GNSS configurations

1.3 Supported GNSS constellations

DAN-F10N is a concurrent GNSS receiver that can receive and track multiple GNSS systems. The dual-band RF front-end architecture enables concurrent reception of multiple dual frequency GNSS constellations. To achieve lower power consumption, the receiver can be configured for a subset of GNSS constellations.

³ The GPS L5 signal health status is ignored. Using the L5 signal requires a configuration change.

⁴ Minimum 98% fix rate under typical conditions.

⁵ CEP, 50%, 24 hours static, -130 dBm, > 6 SVs for each GNSS system.

⁶ Commanded starts. All satellites signals at -130 dBm. Measured at room temperature.

⁷ Depends on the speed and latency of the aiding data connection, commanded starts.

⁸ Using seven days old AssistNow Offline data. External memory may be required.

⁹ Using two days old orbital predicted data. External memory may be required.

¹⁰ Demonstrated with a good external LNA. Measured at room temperature.

The default configuration on DAN-F10N is concurrent reception of GPS, Galileo and BeiDou with SBAS enabled.



Single-band operation is not supported. Both L1 and L5 signals must be enabled or disabled for GPS, Galileo, BeiDou, and QZSS.

The following GNSS and their signals are supported:

System	Signals
GPS / QZSS	L1C/A (1575.42 MHz), L5 (1176.450 MHz)
Galileo	E1-B/C (1575.42 MHz), E5a (1176.450 MHz)
BeiDou	B1C (1575.42 MHz) , B2a (1176.450 MHz)
NavIC	SPS-L5 (1176.450 MHz)

Table 4: Supported GNSS and signals on DAN-F10N

The following GNSS assistance services are supported:

Service	Support
AssistNow™ Online	GPS L1C/A, Galileo E1, QZSS L1C/A
AssistNow™ Offline	GPS L1C/A, Galileo E1, QZSS L1C/A
AssistNow™ Autonomous	GPS L1C/A, Galileo E1

Table 5: Supported Assisted GNSS (A-GNSS) services

The following augmentation systems are supported:

System	Support
SBAS ¹¹	EGNOS, GAGAN, MSAS, WAAS, BDSBAS, KASS and SouthPAN
QZSS	L1S (SLAS), L1Sb (SBAS)

Table 6: Supported augmentation systems

The QZSS augmentation system can be enabled only if GPS operation is also enabled.

1.4 Supported protocols

DAN-F10N supports the following interface protocols:

Protocol	Type
UBX	Input/output, binary, u-blox proprietary
NMEA versions 2.1, 2.3, 4.0, 4.10 and 4.11 (default)	Input/output, ASCII

Table 7: Supported protocols

1.5 Firmware features

Feature	Description
Assisted GNSS	AssistNow Online, AssistNow Offline and AssistNow Autonomous
Backup modes	Hardware backup mode and software standby mode
Protection level	Real-time position accuracy estimate with 95% confidence level ¹²

¹¹ Ionospheric correction service is the only SBAS service supported by DAN-F10N

¹² Verified for automotive environment only.

Feature	Description
Galileo return link messages	Galileo search and rescue (SAR) return link messages (RLM) via Galileo satellite signal
Odometer	Measure traveled distance with support for different user profiles

Table 8: Firmware features

Feature	Description
Anti-jamming	RF interference and jamming detection and reporting
Anti-spoofing	Spoofing detection and reporting
Configuration lockdown	Receiver configuration can be locked by command
Message integrity	All messages can be cryptographically signed
Secure boot	Only signed firmware images are executed

Table 9: Security features

1.6 Integrated antenna

The DAN-F10N module integrates an L1, L5 single-feed stacked-patch GNSS antenna. The RF front-end with the SAW-LNA-SAW structure is optimized for the highest immunity against RF interference.

The optimal antenna performance is achieved with a 70 x 70 mm² ground plane. The antenna gain and efficiency may be reduced on a smaller ground plane.



The application PCB is a part of the antenna solution and the PCB size and layout have an impact on the antenna performance.

The operating frequency of the antenna has been tuned in the antenna production. The tuning involves removing small parts of the antenna metalization and may show as scratches in the antenna element.

[Table 10](#) summarizes typical values for the antenna parameters. [Figure 1](#) shows typical E-plane radiation pattern at L1 and L5 bands.

Parameter	L1 band	L5 band	Unit
Frequency	1569 – 1581	1166 – 1186	MHz
Polarization	RHCP	RHCP	-
Peak RHCP gain, typical	3	1	dBic
Efficiency, typical	60	60	%

Table 10: DAN-F10N antenna parameters measured over a 70 x 70 mm² ground plane

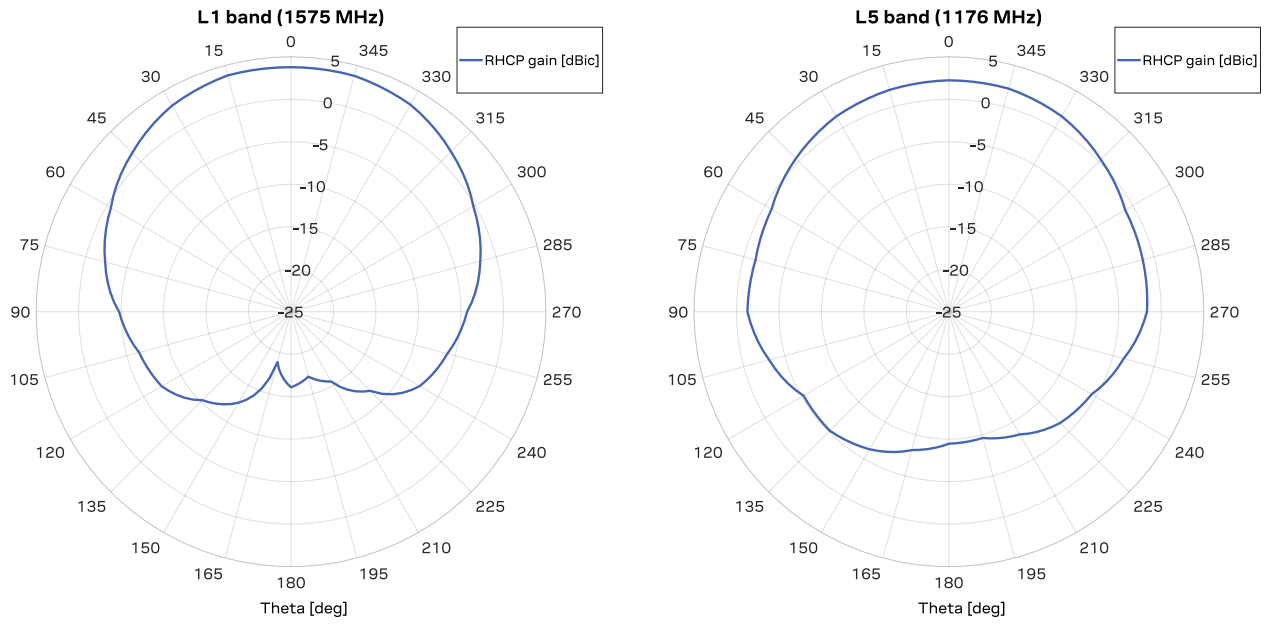

Figure 1: E plane ($\phi = 0$) radiation pattern at the L1 (1575 MHz) and L5 (1176 MHz) bands measured over a 70 x 70 mm² ground plane. Theta = 0 degrees is in the vertical direction.

2 Block diagram

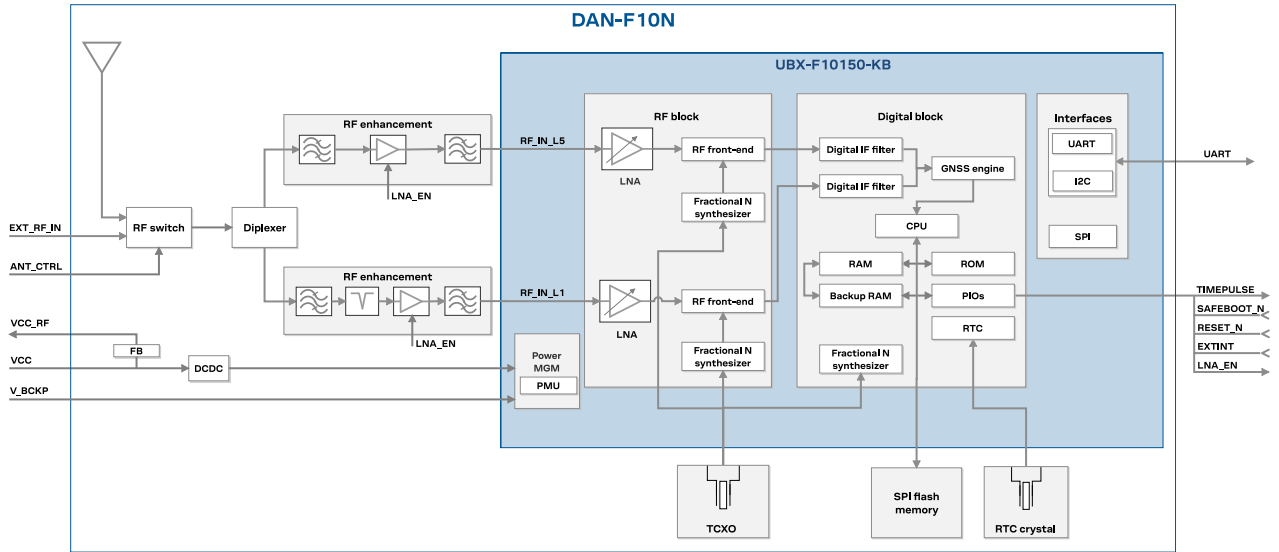

Figure 2: DAN-F10N block diagram

3 Pin definition

3.1 Pin assignment

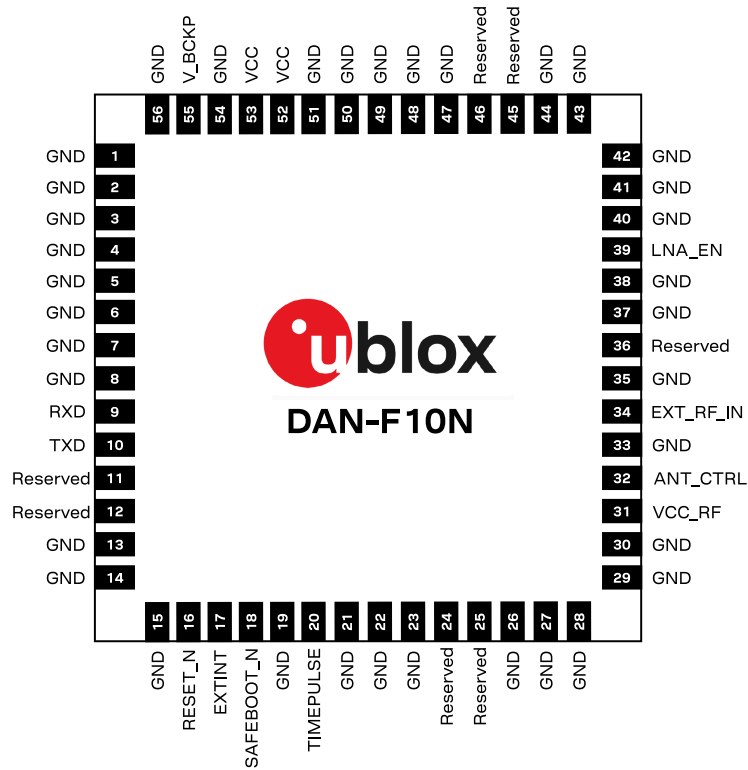

Figure 3: DAN-F10N pin assignment

Pin no.	Name	PIO no.	I/O	Description
1	GND	-	-	Connect to GND
2	GND	-	-	Connect to GND
3	GND	-	-	Connect to GND
4	GND	-	-	Connect to GND
5	GND	-	-	Connect to GND
6	GND	-	-	Connect to GND
7	GND	-	-	Connect to GND
8	GND	-	-	Connect to GND
9	RXD	0	I	UART RX
10	TXD	1	O	UART TX
11	Reserved	-	-	Not connected, leave open
12	Reserved	-	-	Not connected, leave open
13	GND	-	-	Connect to GND
14	GND	-	-	Connect to GND
15	GND	-	-	Connect to GND
16	RESET_N	-	I	System reset (active low). Has to be low for at least 1 ms to trigger a reset.

Pin no.	Name	PIO no.	I/O	Description
17	EXTINT	5	I	External interrupt. Leave open if not used.
18	SAFEBOOT_N	-	I	Safeboot mode (active low). Leave open if not used. ¹³
19	GND	-	-	Connect to GND
20	TIMEPULSE	4	O	Time pulse signal (shared with SAFEBOOT_N pin)
21	GND	-	-	Connect to GND
22	GND	-	-	Connect to GND
23	GND	-	-	Connect to GND
24	Reserved	-	-	Not connected, leave open
25	Reserved	-	-	Not connected, leave open
26	GND	-	-	Connect to GND
27	GND	-	-	Connect to GND
28	GND	-	-	Connect to GND
29	GND	-	-	Connect to GND
30	GND	-	-	Connect to GND
31	VCC_RF	-	O	Output voltage RF section
32	ANT_CTRL	-	I	Choose either internal or external antenna. Low on the pin selects the internal antenna (default). High on the pin selects the external antenna.
33	GND	-	-	Connect to GND
34	EXT_RF_IN	-	I	RF signal input for external antenna
35	GND	-	-	Connect to GND
36	Reserved	-	-	Not connected, leave open
37	GND	-	-	Connect to GND
38	GND	-	-	Connect to GND
39	LNA_EN	-	O	On/Off external LNA or active antenna
40	GND	-	-	Connect to GND
41	GND	-	-	Connect to GND
42	GND	-	-	Connect to GND
43	GND	-	-	Connect to GND
44	GND	-	-	Connect to GND
45	Reserved	-	-	Not connected, leave open
46	Reserved	-	-	Not connected, leave open
47	GND	-	-	Connect to GND
48	GND	-	-	Connect to GND
49	GND	-	-	Connect to GND
50	GND	-	-	Connect to GND
51	GND	-	-	Connect to GND
52	VCC	-	I	Supply voltage
53	VCC	-	I	Supply voltage
54	GND	-	-	Connect to GND
55	V_BCKP	-	I	Backup voltage supply

¹³ The receiver enters safeboot mode if this pin is low at startup. The SAFEBOOT_N pin is internally connected to TIMEPULSE pin through a 1 kΩ series resistor.

Pin no.	Name	PIO no.	I/O	Description
56	GND	-	-	Connect to GND

Table 11: DAN-F10N pin assignment

4 Electrical specifications

4.1 Absolute maximum ratings

- ⚠ CAUTION. Risk of device damage. Exceeding the absolute maximum ratings may affect the lifetime and reliability of the device or permanently damage it. Do not exceed the absolute maximum ratings.
- ⚠ This product is not protected against overvoltage or reversed voltages. Use appropriate protection to avoid device damage from voltage spikes exceeding the specified boundaries.

Symbol	Parameter	Min	Max	Unit
VCC	Main supply voltage	-0.3	3.6	V
	Voltage ramp on VCC ¹⁴	25	35000	μs/V
V_BCKP	Backup supply voltage	-0.3	3.6	V
V_PIO	Input voltage on RESET_N and digital pins	-0.3	VCC + 0.3 (max 3.6)	V
I_PIO	Max source / sink current, digital pins ¹⁵	-10	10	mA
ICC_RF	Max source current, VCC_RF		250	mA
V_DC _{rfin}	DC voltage at EXT_RF_IN	-5.5	+5.5	V
P _{rfin}	RF input power at EXT_RF_IN ¹⁶		0	dBm
T _{amb}	Ambient temperature	-40	+85	°C
T _s	Storage temperature	-40	+85	°C

Table 12: Absolute maximum ratings

4.2 Operating conditions

Table 13 shows the general operating conditions. Table 14 shows the electrical parameters for digital I/O.

Symbol	Parameter	Min	Typical	Max	Unit
VCC	Main supply voltage	2.7	3.0	3.6	V
V_BCKP	Supply voltage, backup domain	1.65		3.6	V
VCC _{SWITCH}	VCC voltage threshold to switch an internal supply for the backup domain from VCC to V_BCKP		1.45		V
VCC_RF	VCC_RF output voltage		VCC - 0.1		V
ICC_RF	VCC_RF output current			50	mA
Z _{in} ¹⁷	Input impedance at EXT_RF_IN		50		Ω
NF _{tot}	Receiver chain noise figure (L1)		3		dB
	Receiver chain noise figure (L5)		3		dB
Ext_gain ¹⁸	External gain at EXT_RF_IN, normal gain mode (default)			25	dB

¹⁴ Exceeding the voltage ramp speed may permanently damage the device.

¹⁵ The SAFEBOOT_N pin has an internal 1 kΩ series resistor.

¹⁶ Test conditions: source impedance = 50 Ω, continuous wave.

¹⁷ The EXT_RF_IN input integrates a built-in DC block.

¹⁸ The internal LNA gain is configurable.

Symbol	Parameter	Min	Typical	Max	Unit
T_{opr}	Operating temperature	-40		+85	°C

Table 13: General operating conditions

Symbol	Parameter	Min	Typical	Max	Unit
I_{leak}	Leakage current input pins ¹⁹		25		nA
V_{in}	Input pin voltage range	0		VCC	V
V_{il}	Low-level input voltage			0.63	V
V_{ih}	High-level input voltage	0.68 x VCC			V
V_{ol}	Low-level output voltage, $I_{out} = -2 \text{ mA}$ ²⁰			0.4	V
V_{oh}	High-level output voltage, $I_{out} = 2 \text{ mA}$ ²⁰	VCC - 0.4			V
$R_{pu, IO}$	Pull-up resistance, Digital IO	8	18	40	kΩ
$R_{pd, IO}$	Pull-down resistance, Digital IO	21	80	180	kΩ
$R_{pu, SAFEBOOT_N}$	Pull-up resistance, SAFEBOOT_N ²¹	6	17	72	kΩ
$R_{pu, RESET_N}$	Pull-up resistance, RESET_N	7	10	13	kΩ

Table 14: Digital IO

4.3 Indicative power requirements

This section provides examples of typical current requirements. They have been characterized on samples using a cold start command. The actual power requirements may vary depending on the firmware version used, the external circuitry, the number of satellites tracked, the signal strength, the type and time of start, duration, internal LNA gain mode, and the test conditions.

All values in [Table 15](#) and [Table 16](#) have been measured at 25 °C ambient temperature with the default configuration unless otherwise stated. SBAS is active in all measurements.

[Table 15](#) shows indicative current consumption for VCC with a 3.0 V supply.

Symbol (Parameter)	Conditions	GPS+GAL +BDS (Default)	GPS+BDS	GPS+GAL	GPS +NavIC	GPS	BDS	Unit
I_{VCC} ²²	Acquisition ²³	26	26	22	21	20	24	mA
(VCC current)	Tracking	21	20	19	18	18	19	mA

Table 15: Typical currents for 3.0 V supply at VCC

The inrush current can go up to 100 mA at startup. Ensure that the external power supply is able to deliver up to 100 mA.

[Table 16](#) shows current consumption for backup modes.

Symbol	Parameter	Conditions	Typical	Unit
I_{V_BCKP} ²⁴	Total current in hardware backup mode	$V_BCKP = 3.0 \text{ V}; VCC = 0 \text{ V}$	31	μA

¹⁹ $V_{in} = VCC$, at room temperature.

²⁰ TIMEPULSE has 4 mA current drive/sink capability.

²¹ The SAFEBOOT_N pin has an additional 1 kΩ series resistor.

²² 1 Hz navigation update rate. Simulated signals using power levels of -130 dBm.

²³ Average current from start-up until the first fix.

²⁴ I_{V_BCKP} current in normal operation ($V_BCKP = 3.0 \text{ V}$) is ~3 μA.

Symbol	Parameter	Conditions	Typical	Unit
I_{VCC}	Total current in software standby mode	VCC = 3.0 V	49	μA

Table 16: Backup currents

Extreme operating temperatures can significantly impact the specified values. If an application operates near the min or max temperature limits, ensure the specified values are not exceeded.

5 Communication interfaces

The receiver supports communication over the UART only.

All the inputs have an internal pull-up resistor in normal operation and can be left open if not used. The voltage level at the PIO pins is related to the

5.1 UART

The UART interface supports configurable baud rates. Hardware flow control is not supported. UART specifications are described in [Table 17](#).

Symbol	Parameter	Min	Max	Unit
R_u	Baud rate	9600	921600	bit/s
Δ_{Tx}	Tx baud rate accuracy	-1%	+1%	-
Δ_{Rx}	Rx baud rate tolerance	-2.5%	+2.5%	-

Table 17: UART specifications

5.2 Default interface settings

Interface	Settings
UART	<ul style="list-style-type: none"> Input messages: NMEA and UBX Output messages: NMEA GGA, GLL, GSA, GSV, RMC, VTG and TXT

Table 18: Default interface settings

6 Mechanical specifications

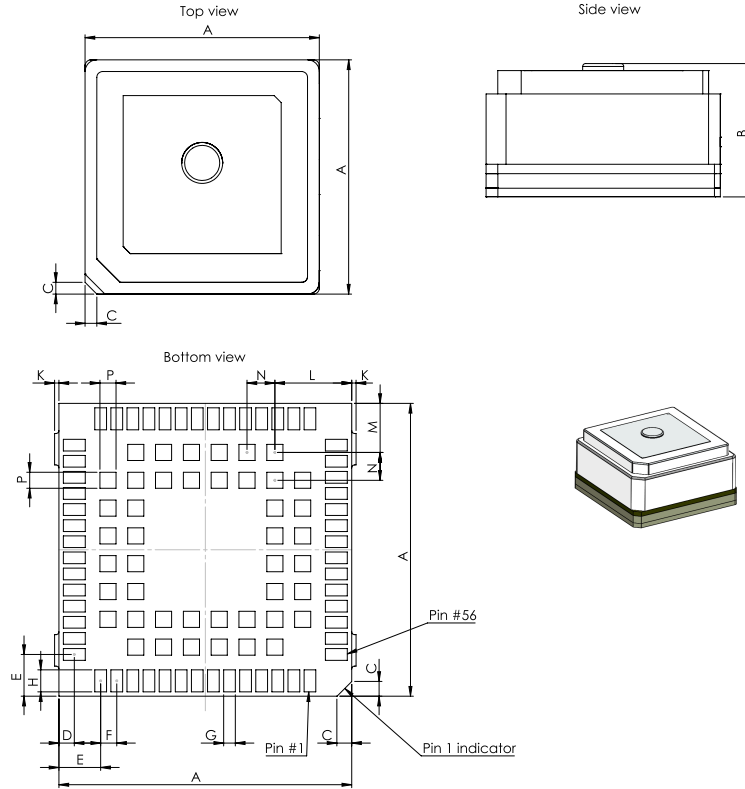

Figure 4: DAN-F10N mechanical drawing

Symbol	Min (mm)	Typical (mm)	Max (mm)
A	-	20.0	-
B	-	11.6	-
C	-	1.0	-
D	-	1.05	-
E	-	2.85	-
F	-	1.1	-
G	-	0.8	-
H	-	1.5	-
K	-	0.3	-
L	-	5.25	-
M	-	3.35	-
N	-	1.9	-
P	-	1.1	-
Weight		18 g	

Table 19: DAN-F10N mechanical dimensions



Take the size of the de-paneling residual tabs into account when designing the component keepout area.

7 Qualifications and approvals

Type	Description
Quality and reliability	
Manufacturing	Manufactured at ISO/TS 16949 certified sites
Environmental	
Moisture sensitivity level (MSL) ^{25, 26}	4

Table 20: Qualifications and approvals

²⁵ For MSL standard see IPC/JEDEC J-STD-020 and J-STD-033 [5].

²⁶ For more information regarding moisture sensitivity levels, labeling, storage, and drying, see the Product packaging reference guide [4].

8 Product handling

8.1 Packaging

The DAN-F10N modules are delivered as hermetically sealed, reeled tapes to enable efficient production, production lot set-up and tear-down. For more information, see the Product packaging reference guide [\[4\]](#).

8.1.1 Reels

DAN-F10N modules are deliverable in quantities of 150 pieces on a reel. They are shipped on reel type A4, as specified in the Product packaging reference guide [\[4\]](#).

8.2 Soldering

Reflow soldering is described in the IPC/JEDEC J-STD-020 standard [\[5\]](#).

9 Product marking and ordering information

This section provides information about product marking and ordering.

9.1 Product marking

The product marking provides information on DAN-F10N and its revision, as in [Figure 5](#). For a description of the product marking, see [Table 21](#)

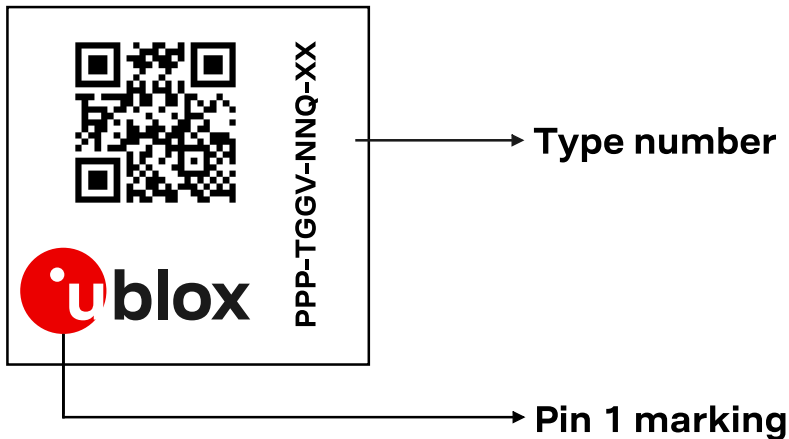

Figure 5: Example of DAN-F10N product marking

Code	Meaning	Example
PPP	Form factor	DAN
TGG	Platform	F10 = u-blox F10
V	Variant	N = Standard precision, flash, TCXO, SAW filter, and LNA
NN	Major product version	00, 01, 02, ...
Q	Product grade	A = Automotive, B = Professional
XX	Revision	Hardware and firmware versions

Table 21: Description of product marking

9.2 Product identifiers

The DAN-F10N marking features three product identifiers: product name, ordering code and type number. The product name identifies all u-blox products, independent of packaging and product grade, and it is used in documentation such as this data sheet. The ordering code includes the major product version and product grade, while the type number additionally includes the hardware and firmware versions.

[Table 22](#) describes the three different product identifiers used in the DAN-F10N module product marking.

Identifier	Format	Example
Product name	PPP-TGGV	DAN-F10N
Ordering code	PPP-TGGV-NNQ	DAN-F10N-00B
Type number	PPP-TGGV-NNQ-XX	DAN-F10N-00B-00

Table 22: Product identifiers

9.3 Ordering codes

Ordering code	Product	Remark
DAN-F10N-00B	u-blox F10, 56 pin LCC, dual-band GNSS antenna module, professional grade	

Table 23: Product ordering codes

u-blox provides information on product changes affecting the form factor, size or function of the product. For the Product change notifications (PCNs), see our website at: <https://www.u-blox.com/en/product-resources>.

Related documents

- [1] DAN-F10N Integration manual, [UBXDOC-963802114-13252](#)
- [2] u-blox F10 SPG 6.00 Interface description, [UBX-23002975](#)
- [3] u-blox F10 SPG 6.00 Release note, [UBXDOC-963802114-12318](#)
- [4] Product packaging reference guide, [UBX-14001652](#)
- [5] Joint IPC/JEDEC standard, www.jedec.org



For regular updates to u-blox documentation and to receive product change notifications please register on our homepage <https://www.u-blox.com>.

Revision history

Revision	Date	Comments
R01	12-Dec-2024	Initial release
R02	06-Mar-2025	Prototype Added sections <ul style="list-style-type: none">• Integrated antenna• Qualifications and approvals• Packaging• Soldering Updated sections <ul style="list-style-type: none">• Pin definition• Mechanical specifications

Contact

u-blox AG

Address: Zürcherstrasse 68
8800 Thalwil
Switzerland

For further support and contact information, visit us at www.u-blox.com/support.