

Features

- Complete demonstration platform for the DRM1000 DRM/AM/FM Broadcast Receiver Module
- Antenna connections for MF, HF or VHF
- Push-button selection of: MF/HF/VHF bands, AM/FM/DRM modes, frequency scan, station, volume up and down, storage of up to four saved stations
- Can operate from 3 AA alkaline batteries or 4.5V dc power supply
- OLED user display
- Built-in 2-inch loudspeaker and headphone output



Figure 1 - Demonstration platform for the DRM1000 DRM/AM/FM Broadcast Receiver Module

1 Brief Description

The DE9180 is a compact demonstration platform that allows the functionality of the DRM1000 AM/FM Broadcast Receiver Module to be easily demonstrated. The DRM1000 module is supplied soldered directly to the PCB, as it would be in an end-product.

The DE9180 provides a full complement of inputs, outputs, and controls to allow the performance of the DRM1000 to be assessed. Included are external power supply connector, headphone socket, connection for an external HF/VHF antenna, connection for an external MF antenna, loudspeaker, battery holder and 16x2-character OLED display. Also included is a 12-button keypad that provides for adjustment of volume level (up and down), station selection, frequency band selection, four pre-set station memory buttons, frequency scan, and other user functions.

A separate ferrite rod antenna may be mounted on the underside of the DE9180.

This document refers to the latest version of the DE9180 when used with a DRM1000 module loaded with the latest firmware.

CONTENTS

1	Brief Description	3
2	History	2
3	Block Diagrams	3
4	Preliminary Information	4
4.1	Laboratory Equipment.....	4
4.1.1	Power Supply.....	4
4.2	Handling Precautions	4
4.2.1	SSD Devices	4
4.2.2	Contents – Unpacking	4
4.3	Approvals.....	4
5	Quick Start	4
5.1	Setting-Up	4
5.2	Operation	5
6	Signal Lists	6
7	Circuit Schematics and Board Layouts	8
8	Detailed Description	9
8.1	Hardware Description	9
8.1.1	Power Supplies	9
8.1.2	Antenna Inputs.....	9
8.1.3	Display and Control	10
8.1.4	Audio Outputs	10
8.2	Adjustments and Controls.....	10
8.3	Application Information	12
8.3.1	Ferrite Rod Antenna	12
8.3.2	Air Loop Antenna.....	12
8.3.3	Telescopic Antenna	12
8.4	Troubleshooting	13
9	Performance Specification	14
9.1	Electrical Performance	14
9.1.1	Absolute Maximum Ratings	14
9.1.2	Operating Limits	14
9.1.3	Operating Characteristics	14

CONTENTS

<u>Tables</u>	<u>Page</u>
Table 1 - User Connector Pinouts	6
Table 2 - Test Points	7
Table 3 - Test Loops	7
Table 4 - Jumpers.....	7
Table 5 - Switches	7
Table 6 - Switch Matrix	10
Table 7 - Button Functions.....	11
Table 8 - Troubleshooting.....	13
Table 9 - Absolute Maximum Ratings	14
Table 10 - Operating Limits.....	14
Table 11 - Operating Characteristics.....	14

<u>Figures</u>	<u>Page</u>
Figure 1 - Demonstration platform for the DRM1000 DRM/AM/FM Broadcast Receiver Module	3
Figure 2 - DRM1000 Block Diagram	3
Figure 3 - DE9180 Kit Block Diagrams.....	3
Figure 4 - Typical Connections for DE9180	5
Figure 5 - PCB Layout: Top.....	8
Figure 6 - PCB Layout: Bottom	9
Figure 7 - Display Module	11
Figure 8 - Typical 'AM Air Loop' Antenna.....	12

It is recommended that you check for the latest product datasheet version from the Products page of the CML website: www.cmlmicro.com.

This is Advance Information; changes and additions may be made to this document. Parameters marked TBA or left blank will be included in later issues of this document.

2 History

Version	Changes	Date
1.0	First Approved Release	16 th May 2024

3 Block Diagrams

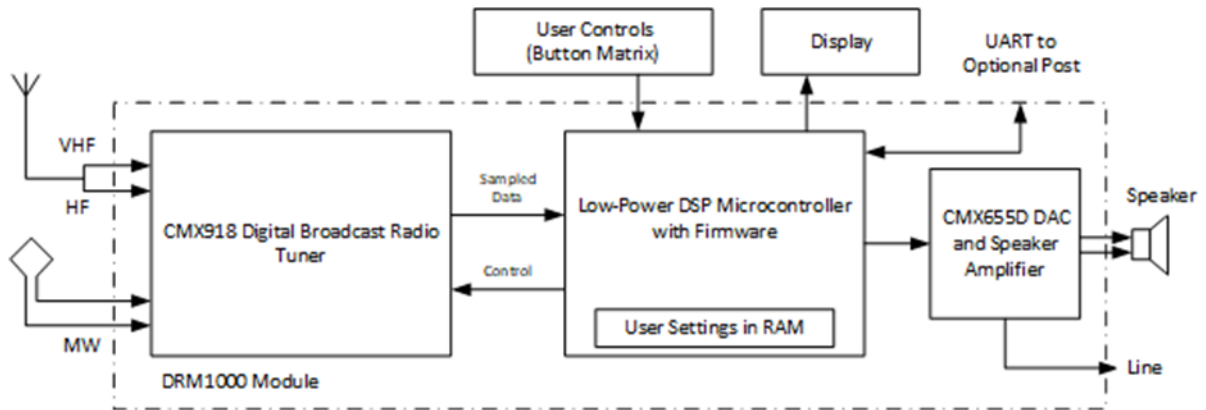

Figure 2 - DRM1000 Block Diagram

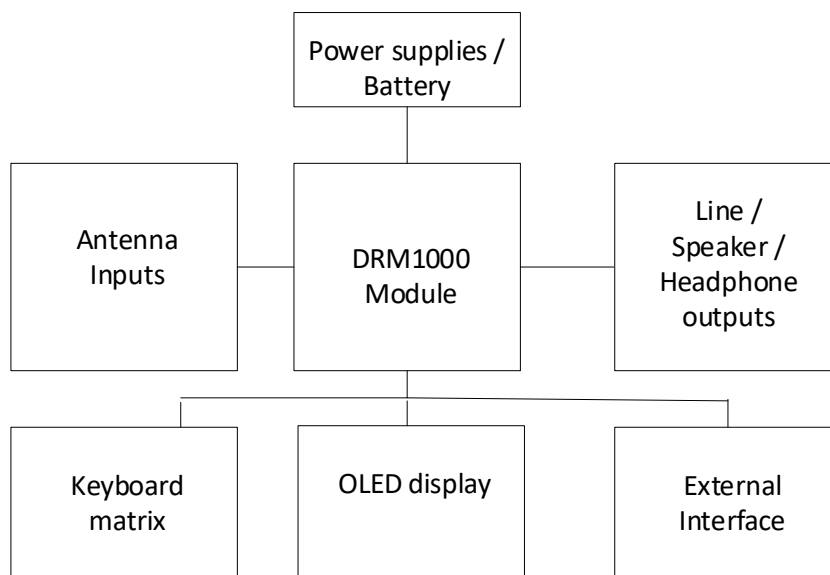

Figure 3 - DE9180 Kit Block Diagrams

4 Preliminary Information

The DE9180 provides a complete platform for demonstrating the DRM1000 receiver module.

4.1 Laboratory Equipment

The following items are required for demonstration of the DRM1000 with the DE9180:

- Laboratory power supply
- DRM /AM / FM RF signal generator / source
- Optional PC for external control, using FTDI interface cable C232HD-DDHSP-0

4.1.1 Power Supply

The input voltage to the PCB at J1 is nominally 4.5 V (limits: Minimum 3.5 V to maximum 5.0 V). The input power supply should be rated at 500 mA.

There is also a battery connector J2. Both inputs are reverse polarity protected using a series diode.

Note: Do not connect a power supply to the DE9180 if batteries are inserted as this may cause component damage.

4.2 Handling Precautions

This product is designed for use in office and laboratory environments. The following practices will help ensure its proper operation.

4.2.1 SSD Devices



This product uses low-power CMOS circuits that can be damaged by electrostatic discharge. Partially-damaged circuits can function erroneously, leading to misleading results. Observe ESD precautions at all times when handling this product.

4.2.2 Contents – Unpacking

Please ensure that you have received all the items on the separate information sheet (EK9180) and notify CML within seven working days if the delivery is incomplete.

4.3 Approvals

This product is not approved to any EMC or other regulatory standard. Users are advised to observe local statutory requirements, which may apply to this product and the radio frequency signals that may emanate from it.

5 Quick Start

This section provides instructions for users who wish to experiment immediately with this Demonstration Kit. A more complete description of the kit and its uses appears later in this document. The user should also read the DRM1000 datasheet before using the board.

5.1 Setting-Up

The following procedure is recommended (refer also to Figure 4):

1. For battery operation, fit 3 x AA batteries to the holder, observing the correct polarity.
2. Otherwise, apply external power to J1, observing the correct polarity (note that external power must not be applied simultaneously with batteries).
3. Slide the Power switch to the on position. The display will briefly show 'DRM1000' along with the firmware version, then after a short delay show the mode, frequency etc.
4. Connect the signal source or antenna for HF (short-wave) or VHF ('FM band') to the SMA antenna connector J10. MF (medium-wave) reception may use a ferrite rod antenna connected at ANT1 (ANT_P & ANT_N) or an 'air-loop' antenna at J9. Alternatively, the SMA connector J10 can be configured for MF signal input via the selection link JP5.

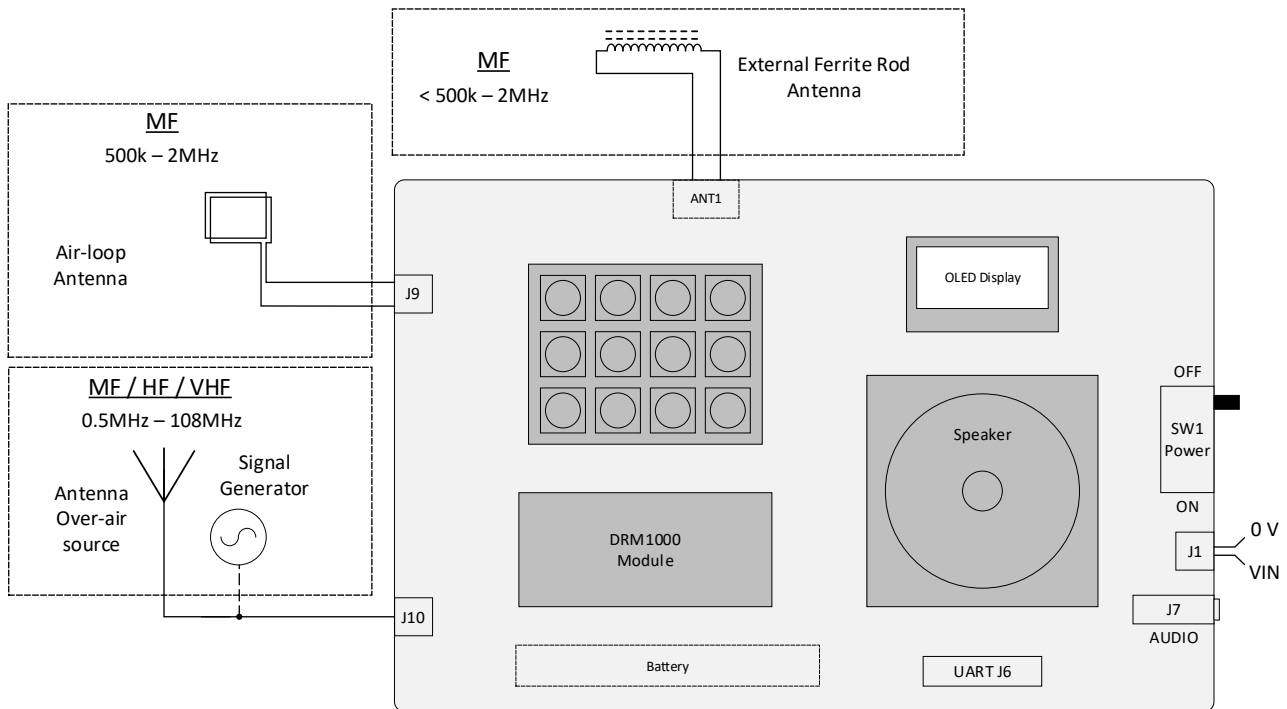

Figure 4 - Typical Connections for DE9180

5.2 Operation

Use the controls on the DE9180 as follows:

1. Select the frequency band required using the MF/HF/VHF button. The display will show the selected band.
2. On first use with DRM press the AM/FM/DRM mode button to select DRM in the display. Place the DE9180 in a location where there is good radio reception (e.g. outdoors or close to a window) and press the SCAN button for at least 2 seconds. All bands and modes for which reception is enabled will then be scanned, and the display will show SCANNING and a progress bar until the process has ended. The number of stations found is briefly displayed at the end of the scan.
3. To select a station, press STATION + or STATION - which will select the next station found.
4. The loudspeaker will produce sound, and its volume can be adjusted by the VOLUME + and VOLUME - buttons. Headphones (> 4 to 16 Ω) can be connected to the headphone jack J7. The headphone output is mono but via a 'stereo' TRS connector (tip and ring in parallel). **Note that the sleeve must not be grounded and inserting a mono plug will short the output.** Any headphone or audio leads connected should be less than 300 cm long. Performance with longer leads cannot be guaranteed.
5. To store a station for quick recall, find the station, then press one of the 1, 2, 3, 4 memory buttons for at least 2 seconds to store the station. A short press on one of the memory buttons will recall. There are four memory locations in total.

Note that inserting a connector into the headphone output J7 will mute the on-board speaker output.

For full operating instructions, please see the datasheet for the DRM1000 module.

6 Signal Lists

Table 1 - User Connector Pinouts

USER CONNECTOR PINOUTS				
Connector Ref.	Connector Pin No.	Signal Name	Signal Type	Description
J1	1	+V	DC	4.5 V Power supply input
J1	2	GND	DC	Power supply ground
J2	1	+V	DC	Battery +
J2	2	GND	DC	Battery -
J3	1	I2S_DATA_CS		(DRM1000 future option)
J3	2	I2S_DATA_SDA		(DRM1000 future option)
J3	3	I2S_DATA_SCLK		(DRM1000 future option)
J3	4	GND	DC	Ground
J4	1	I2S_AUDIO_FRAME		I2S audio output (DRM1000 option)
J4	2	I2S_AUDIO_DATA		I2S audio output (DRM1000 option)
J4	3	I2S_AUDIO_SCLK		I2S audio output (DRM1000 option)
J4	4	GND	DC	Ground
J5	1	VCC	DC	Supply for display module
J5	2	GND	DC	Ground for display module
J5	3	I2C_SCK		Clock for display module
J5	4	I2C_SDA		Data for display module
J6	1	RESET	data	Reset
J6	2	UART_RX	data	Output data interface
J6	3	UART_TX	data	Input data interface
J6	4	GND	DC	Ground
J7	N/A		AF	3.5mm Headphone output (TRS)
J9	2	LF_SIG_P	RF	Low impedance LF/MF input
J9	1	LF_SIG_N / GND	RF	Low impedance LF/MF input
ANT1	4	CBN	RF	Primary winding tuning / capacitor bank
ANT1	3	CBP	RF	Primary winding tuning / capacitor bank
ANT1	1	LF_IN_P	RF	High impedance LF/MF input
ANT1	2	LF_IN_N	RF	High impedance LF/MF input
J10	N/A	-	RF	HF / VHF input
J11	1-2	BT_UART_TX	data	Bluetooth data option (not fitted)
J11	3-4	BT_UART_RX	data	Bluetooth data option (not fitted)
J12	A	GPIO0		EWf
J12	B	GPIO6		STBY_ON
J13	1	SPKR_N_OUT	AF	Not fitted
J13	2	SPKR_P_OUT	AF	Not fitted
J13	3	GND	AF	Not fitted
J14	1	LF_SIG_P	RF	Low impedance LF/MF input
J14	2	LF_SIG_N / GND	RF	Low impedance LF/MF input

Table 2 - Test Points

TEST POINTS		
Test Point Ref.	Typical Measurement	Description
TP1	+4.5 V	Input power test
TP2	+ 3.3 V	VCC test
TP3	+3.3 V	RESETN
J8 -1	-	Line level audio test output
J8-2	-	Audio ground

Table 3 - Test Loops

TEST LOOPS		
Test Point Ref.	Typical Measurement	Description
TL1	-	GND
TL3	-	1.8 V monitor
TL4	-	Feedback for LNA

Table 4 - Jumpers

Jumpers		
Jumper Ref.	Default Configuration	Description
JP1	Fitted	LF_IN_P routing for low impedance connection
JP2	Fitted	LF_IN_N routing for low impedance connection
JP3	Not Fitted	LF_IN_P routing for ferrite rod antenna
JP4	Not Fitted	LF_IN_N routing for ferrite rod antenna
JP5	2-3	1-2 J10 connection for MF input 2-3 J10 connection for HF/VHF input
JP6	Fitted	DRM1000 VHF input direct / via diplexer if link fitted
JP7	Fitted	DRM1000 HF input direct / via diplexer if link fitted
JP8	Not Fitted	Enable link for linear audio amplifier U5
JP9	Fitted	Output link for DRM1000 audio amplifier
JP10	Fitted	Output link for DRM1000 audio amplifier
JP11	Not Fitted	Output link for U5 linear audio amplifier
JP12	Not Fitted	Output link for U5 linear audio amplifier
JP13	-	BT_MODE (not fitted)
JP14	Fitted	DRM1000 VDD_PA audio current monitor

Table 5 - Switches

Switches	
Switch Ref.	Description
SW1	1-2 (up) = Off 2-3 (down) = On
SW2	Reset (push button)

7 Circuit Schematics and Board Layouts

For clarity, the circuit schematic diagrams are available as separate high-resolution files, which can be downloaded from the CML website. The layouts for each side of the PCB are shown in the following two diagrams.

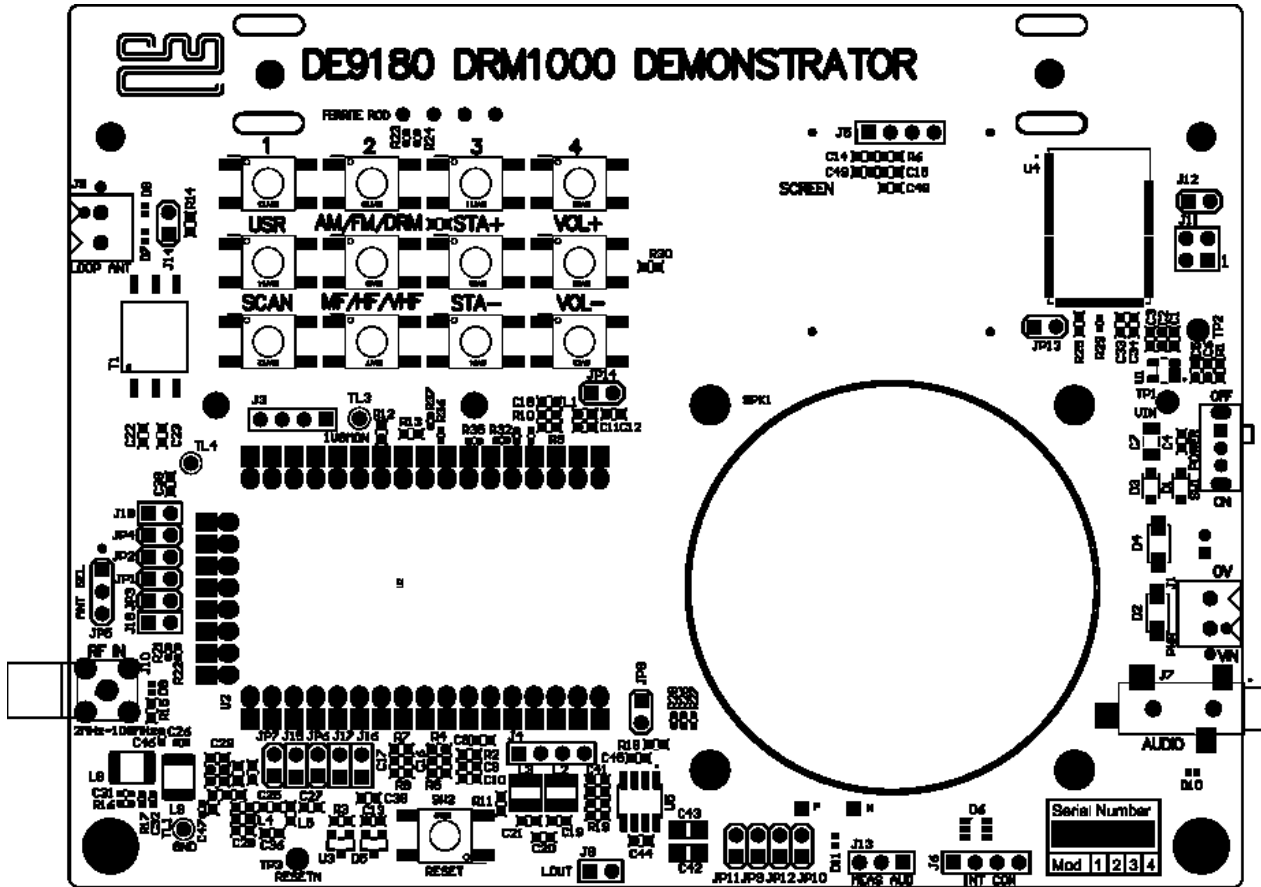

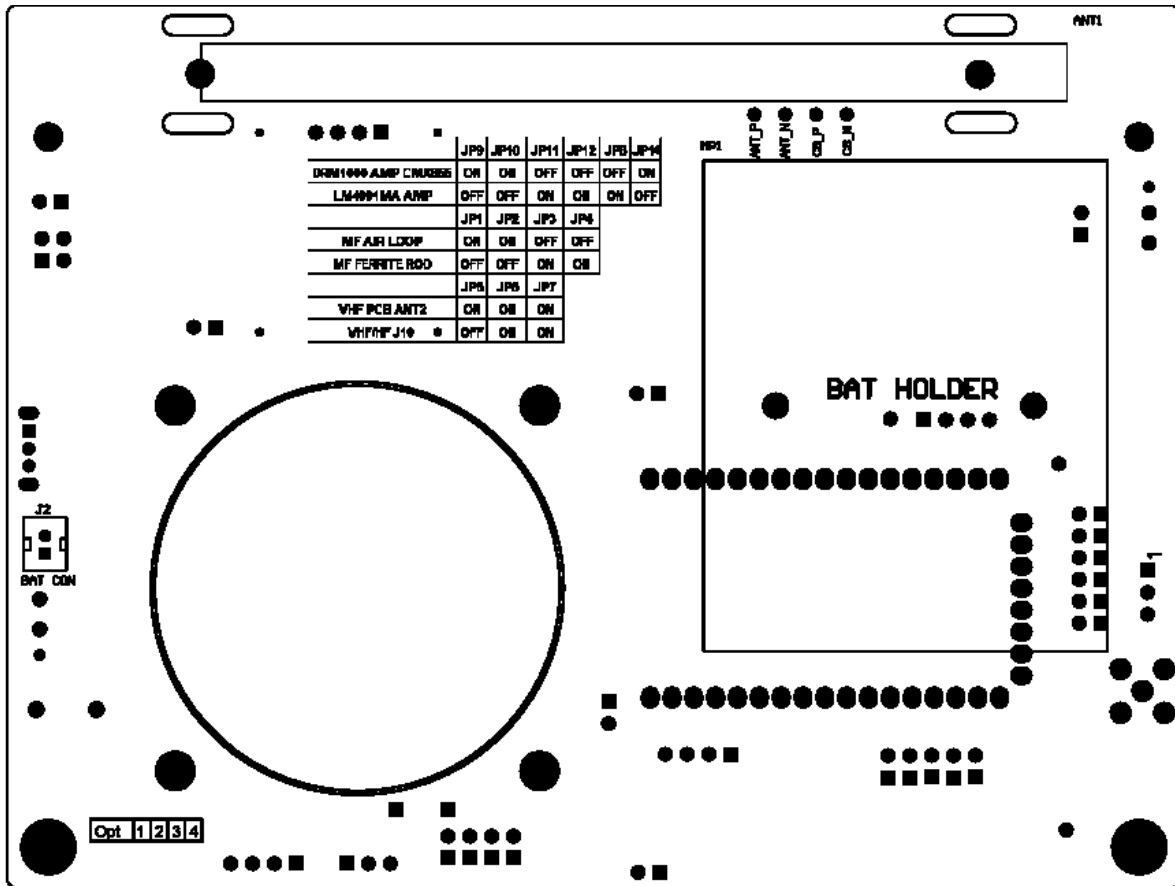

Figure 6 - PCB Layout: Bottom

8 Detailed Description

The DE9180 functionality includes:

- The DRM1000 Broadcast Receiver Module
- Power supply connections
- Antenna interfaces
- User interface (3 x 4 push button matrix)
- User display
- 2" speaker and headphone output

8.1 Hardware Description

Full details of the DRM1000 module is contained within its own separate datasheet. The DE9180 is assembled on a 136 mm x 103 mm, 1.6 mm thick 4-layer PCB (reference PCB780F), using FR4 / VT481 2116 dielectric.

A schematic, Gerber files and a BOM can be downloaded from the CML website.

8.1.1 Power Supplies

An on-board low drop out linear regulator provides the 3.3 V supply to the DRM1000 module and associated circuits.

8.1.2 Antenna Inputs

A 50 Ω SMA input J10 is provided for RF input on all bands. JP5 selects whether this input is linked to the MF inputs via transformer T1 or to the HF/VHF inputs. On the HF/VHF path, a high pass filter is used to attenuate strong MF signals. This is followed by a diplexer circuit to split the signal to the separate HF and VHF DRM1000 input pins.

There is facility for the user to bypass the input filters, develop preamplifiers or add a high impedance input for HF use on a daughter 'shield' board. VCC is available on J16 and J19 with ground on J15 and J18. J17 provides a signal that is high on HF / low on MF and VHF to enable power saving on such a board when a HF band is not selected. The input can be provided via the pins of JP5 with the output then connecting to the DRM1000 inputs at JP6 and JP7.

The MF band is supported via a low impedance ‘air-loop’ antenna input at J9/J14, via transformer T1. This is selected by removing the jumpers JP3/4 for the ferrite rod antenna and instead linking JP1 and JP2. This input can also be used for low impedance signal sources / RF signal generators to test LF/MF operation. This input can also be optionally linked to the J10 SMA input via JP5.

Alternatively, a high impedance input for a MF ferrite rod antenna secondary winding is provided at ANT1 (ANT_P & ANT_N) via jumpers JP3 and JP4. The ferrite antenna’s primary winding can be resonated using variable capacitors internal to the DRM100 module, provided at the CBP and CBN pins. Resistors R21-R24 allow this to be configured for either a single winding or a tapped / secondary winding ferrite antenna.

8.1.3 Display and Control

An OLED display module provides frequency tuning, mode, signal strength and DRM station information. This is connected to the DRM1000 module via J5. A 3 x 4 switch (push button) matrix provides a user control interface for tuning, volume, station memories, etc.

A 4-way interface (J6) provides the ability to control and monitor the receiver via UART commands. This could allow a more elaborate user interface to be implemented.

8.1.4 Audio Outputs

The Class D audio outputs from the DRM1000 are filtered by the circuitry of L2, L3 etc. to attenuate the switching frequency component. Jumper links JP9 and JP10 connect the filtered output to the loudspeaker or headphones. Alternatively, JP11 and JP12 allow for connection of an alternative linear audio amplifier, U5, to the loudspeaker or headphones if the Class D output of the DRM1000 is not used. JP8 is fitted to enable the U5 amplifier. The two amplifiers and connections to the loudspeaker should not be enabled simultaneously. A low level, single ended LOUT signal is also available at J8.

8.2 Adjustments and Controls

The DE9180 provides adjustments and control via a switch matrix as follows.

Table 6 - Switch Matrix

Switch Matrix			
1	2	3	4
USR	AM/FM/DRM	STA+	VOL+
SCAN	MF/HF/VHF	STA-	VOL-

Table 7 - Button Functions

Button Functions		
Button name	Function: short press < 0.5s	Function: long press ≥ 2s
VOL+	Increase volume by one step	Increase volume continuously while held
VOL-	Decrease volume by one step	Decrease volume continuously while held
STA+	Step up to next scanned station Manual tuning mode, increment selected digit	Tune up in frequency
STA-	Step down to next scanned station Manual tuning mode, decrement selected digit	Tune down in frequency
BAND	Move between MF, HF, VHF bands	-
AM/FM/DRM	Move between DRM mode and AM/FM mode (FM selected automatically for VHF band, otherwise AM)	-
SCAN	Abort scan if already started; Manual tuning enable / move to the next digit right	Scan all bands for stations
USR	Toggle between standby (with wake to receive EWF) and operation	Toggle between off (no receiver function) and operation
1	Retrieve Memory 1	Store current station in Memory 1
2	Retrieve Memory 2	Store current station in Memory 2
3	Retrieve Memory 3	Store current station in Memory 3
4	Retrieve Memory 4	Store current station in Memory 4

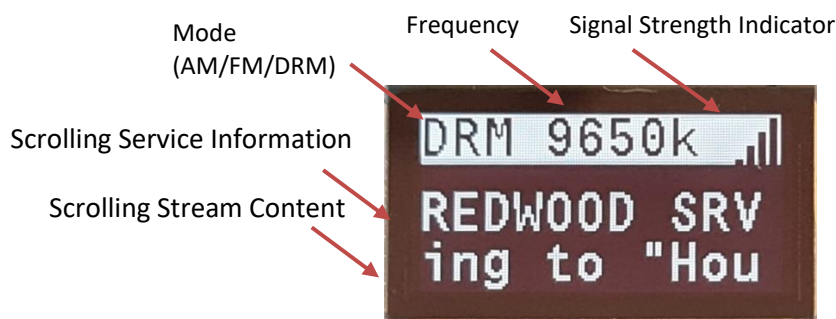

Figure 7 - Display Module

Note: Mode (AM/FM/DRM) and frequency can be changed by the user with the buttons and the service / stream content are set by the broadcaster so will differ from diagram above.

8.3 Application Information

8.3.1 Ferrite Rod Antenna

A Ferrite Rod antenna may be fitted to the underside of the DE9180 for MF band reception. This optional ferrite rod offers two possible configurations:

- A single winding connected to ANT1 (ANT_P & ANT_N), pins 1 and 2 and is tuned via the DRM1000 internal capacitor bank via R21/R22.
- A high impedance primary winding, connected to ANT1 (ANT_P & ANT_N), pins 3 and 4, tuned via the DRM1000 internal capacitor bank via R23/R24, with a secondary winding connected to ANT1, pins 1 and 2 to the DRM1000 LF inputs. In this instance, R21 and R22 should be removed.

For further information, refer to the DRM1000 module datasheet. The ferrite rod should be oriented for best MF reception.

8.3.2 Air Loop Antenna

An 8-turn 'AM Air Loop' antenna (on an approximately 135 x 115 mm former) connected to J9 may be used for MF band reception. This antenna is also directional and should be oriented for best MF reception.



Figure 8 - Typical 'AM Air Loop' Antenna

8.3.3 Telescopic Antenna

A 1.2 m telescopic antenna terminated in an SMA connector using J10 may be used for HF and VHF band reception.

Note: Air-Loop and telescopic antennas are widely available from online retailers.

8.4 Troubleshooting

The DE9180 is a complex system. If incorrectly programmed or modified, results will be at variance from datasheet performance. Please study the DRM1000 datasheet, along with the associated schematics and layout drawings for these carefully when troubleshooting. This section provides suggestions to help users resolve application issues they might encounter.

Table 8 - Troubleshooting

Troubleshooting		
Error Observed	Possible Cause	Remedy
The system will not turn on	Faulty batteries, need replacing	Check that the batteries are good and fully charged. Check battery connection at J2.
	Power supply connection	Check power supply connection at J1
No signal received	Incorrect antenna connection	Check the antenna connection and associated jumper links.
	Incorrect band selected	Check that the correct band is selected at JP5 (MF or HF/VHF) and relevant jumpers have been fitted in the RF input path (MF - JP1 to JP4, HF – JP7 and VHF – JP6)
	Input signal out of range	Check that the input signal is in the correct range (-105 to 0 dBm)
	Incorrect format and coding of signal	If format and coding of signal is correct, reset the system
Signal present but no audio output from the loudspeaker	Incorrect configuration	Check the volume level, the jumper settings to enable the correct audio amplifier (see Table 4) and the headphone connection J7.

9 Performance Specification

9.1 Electrical Performance

9.1.1 Absolute Maximum Ratings

Exceeding these maximum ratings can result in damage to the Demonstration Kit.

Table 9 - Absolute Maximum Ratings

Absolute Maximum Ratings			
	Min.	Max.	Units
Supply ($V_{IN} - V_{SS}$)	0	5.5	V
Current into or out of V_{IN} and V_{SS} pins	0	0.35	A
Current into or out of any other connector pin	-20	+20	mA
Maximum Input Level	-	+10	dBm

9.1.2 Operating Limits

Correct operation of the Demonstration Kit outside these limits is not implied.

Table 10 - Operating Limits

Operating Limits				
	Notes	Min.	Max.	Units
Supply ($V_{IN} - V_{SS}$)		3.5	5.5	V
Ambient Operating Temperature		0	+55	°C

9.1.3 Operating Characteristics

For the following conditions unless otherwise specified: $V_{IN} = 4.5$ V

Table 11 - Operating Characteristics

Operating Characteristics					
	Notes	Min.	Typ.	Max.	Units
DC Parameters					
I_{IN} (standby)	1	-	1	-	mA
I_{IN} (AM Mode, MF)	2	-	59	-	mA
I_{IN} (AM Mode, HF)	2	-	59	-	mA
I_{IN} (FM Mode)	2	-	71	-	mA
I_{IN} (DRM30, Mode B 10 kHz)	2	-	67	-	mA
I_{IN} (DRM+)	2	-	75	-	mA
I_{IN} (FM Mode)	3	-	147	-	mA
Typical RF Performance	4		-		
Digital I/O Interface	4		-		

Notes:

- Standby (from USR button)
- Volume set to 2 levels below maximum, driving a 4 Ω speaker.
- Volume at maximum, driving a 4 Ω speaker.
- Refer to DRM1000 datasheet for details

CML does not assume any responsibility for the use of any circuitry described. No IPR or circuit patent licences are implied. CML reserves the right at any time without notice to change the said circuitry and any part of this product specification. Evaluation kits and demonstration boards are supplied for the sole purpose of demonstrating the operation of CML products and are supplied without warranty. They are intended for use in a laboratory environment only and are not for re-sale, end-use or incorporation into other equipment. Operation of these kits and boards outside a laboratory environment is not permitted within the European Community. All software/firmware is supplied "as is" and is without warranty. It forms part of the product supplied and is licensed for use only with this product, for the purpose of demonstrating the operation of CML products. Whilst all reasonable efforts are made to ensure that software/firmware contained in this product is virus free, CML accepts no responsibility whatsoever for any contamination which results from using this product and the onus for checking that the software/firmware is virus free is placed on the purchaser of this demonstration kit or development board.

	United Kingdom	p: +44 (0) 1621 875500	e: sales@cmlmicro.com techsupport@cmlmicro.com
	Singapore	p: +65 62888129	e: sg.sales@cmlmicro.com sg.techsupport@cmlmicro.com
	United States	p: +1 336 744 5050	e: us.sales@cmlmicro.com us.techsupport@cmlmicro.com
www.cmlmicro.com			