

1

Connectors

Series M

Circular Modular
Connectors

Catalogue [A10.en](#)

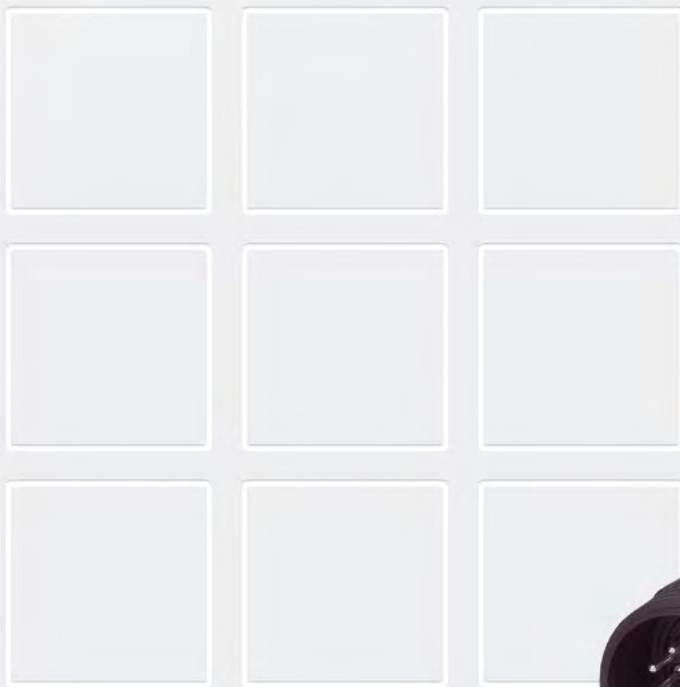

Modular connector system: M1 and M3 Series

M1 and M3 Series universal industrial connectors are designed for safety and reliability in harsh ambient conditions. Vibration, dust, aggressive liquids or vapours are often the cause of failures and serious safety problems. Sealed to IP67 or IP69K, our M1 and M3 Series circular connectors

are dustproof, pressure proof and water protected when mated. They are also resistant to the effects of most acids and alkalines as well as the extremes of temperature.

Features

M1, M3 series

Schaltbau M Series circular connectors have a modular design that allows for many assembly variations to fit your applications.

Common features of M1 and M3 Series:

- **Modular design:** Customized and cost-effective realisation of your applications.
- **Shells:** Various kinds of assembly, e.g. plug and receptacle shells with and without strain relief, with flange, for heat shrink backfittings, for backshells with thread and cable gland, also angled receptacle with flange. Plug and receptacle shell can be fitted with either pin or socket insert, i.e. fully insulated socket inserts can be mounted on the live part.
- **Key positions:** Pin and socket inserts can be located in the shell in two different positions, thus preventing misengagement. It also allows for the unmistakable connection of for example two connectors with different voltages to one and the same piece of equipment.
- **Materials:**
 - Contacts:
 - High-quality machined contacts
 - Gold- or silver-plated surfaces
 - Crimp termination 0.5 ... 6.0 mm² according to contact arrangement
 - Shells:
 - Fibre glass reinforced polyamide: impact resistant, non-halogen, conforming to UL



Connectors M1 and M3 Series compared

Special features of M1 Series:

- Number of contacts: 4 and 6 pole connector + PE
- 5,000 mating cycles at constant low contact resistance
- Max. rated current: 16 A

Special features of M3 Series

- Number of contacts: 6, 8, and 12 pole connector + PE
- 5,000 mating cycles at constant low contact resistance
- Max. rated current: 50 A

Applications

You can use our M1 and M3 Series connectors for various applications, especially where high reliability under harsh environmental conditions is important. Typical applications are: mining, ship-building, power plant construction, mechanical and traffic engineering, environmental technology or food processing. We hold numerous official approvals.













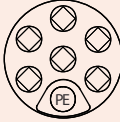
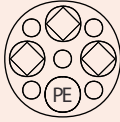
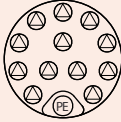
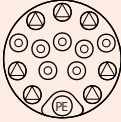





















Standards

M1, M3 series

- Electrical and mechanical characteristics of connectors to IEC 61984
- Degree of protection according to IEC 60529
- Material flammability rating: UL 94-V0
-  us UL approval, UL files E242089
- Germanischer Lloyd

Specifications

M1, M3 series

| Series | M1 | | | M3 | | |
|--|--|--|--|--|--|---|
| Max. # of contacts + PE (Earth contact) | 4-pole + PE | 6-pole + PE | 6-pole + PE | 8-pole + PE | 12-pole + PE | 7+7-pole + PE |
| Contact arrangement |  |  |  |  |  |  |
| Contact identification marked on insert Pin insert: Rear view Socket insert: Front view | PE 1 4 2 3 | PE 1 5 2 3 4 6 | 1 2 5 6 3 4 PE | 6 2 5 3 8 1 7 PE 4 | 9 1 2 8 10 3 7 12 11 4 6 PE 5 | 9 1 2 8 13 10 14 3 7 12 11 4 6 PE 5 |
| Rated voltage (IEC 60038) Pollution degree 3 (IEC 60664-1) |  230 V/400 V  Earth contact |  250 V  Earth contact |  230 V/400 V  Earth contact |  25 V  230 V/400 V  Earth contact |  250 V  Earth contact |  250 V  200 V  Earth contact |
| Key positions for mating | 2 | 2 | 2 | 1 | 2 | 2 |
| Max. rated current of individual contact Contact type/size :  A Ø 1.58 mm  B Ø 2.30 mm  C Ø 4.00 mm |  A 4 x 16 A |  A 6 x 16 A |  B 6 x 32 A |  A 5 x 16 A  C 3 x 50 A |  A 12 x 16 A |  A 14 x 16 A |
| Max. rated current of individual contact depending on wire gauge**: |  A |  A |  B |  A  C |  A |  A |
| 0.50 mm ² | 7.5 A | 7.5 A | 7.5 A | 7.5 A --- | 7.5 A | 7.5 A |
| 0.75 ... 1.00 mm ² | 10 A | 10 A | 10 A | 10 A --- | 10 A | 10 A |
| 1.50 mm ² | 16 A | 16 A | 16 A | 16 A --- | 16 A | 16 A |
| 2.50 mm ² | 16 A | 16 A | 27.5 A | 16 A 27.5 A | 16 A | 16 A |
| 4.00 mm ² | --- | --- | 32 A | --- 35 A | --- | --- |
| 6.00 mm ² | --- | --- | 35 A | --- 50 A | --- | --- |
| Contact resistance (IEC 60512-2) | <3 mΩ | <3 mΩ | <3 mΩ | <3 mΩ | <3 mΩ | <3 mΩ |
| Insulation resistance (IEC 60512-2) | 1 GΩ | 1 GΩ | 1 GΩ | 1 GΩ | 1 GΩ | 1 GΩ |
| Range of operating temperature* | -50°C ... +100°C | -50°C ... +100°C | -50°C ... +100°C | -50°C ... +100°C | -50°C ... +100°C | -50°C ... +100°C |
| Degree of protection (IEC 60529) mated / with protection cap | IP67 / IP69K | IP67 / IP69K | IP67 / IP69K | IP67 / IP69K | IP67 / IP69K | IP67 / IP69K |
| Test standard (IEC 60068-1) (t _{min} [°C]/t _{max} [°C]/t _{testing time} [days]) | -25/+100/21 | -25/+100/21 | -25/+100/21 | -25/+100/21 | -25/+100/21 | -25/+100/21 |
| Mechanical endurance (mating cycles) (IEC 60512-5, test 9a) | 5,000 | 5,000 | 5,000 | 5,000 | 5,000 | 5,000 |
| Materials | | | | | | |
| Shells, flame retardant to UL 94-V0 Polyamide PA6.6 = non-halogen | PA6.6 GF30 black | PA6.6 GF30 black | PA6.6 GF30 black | PA6.6 GF30 black | PA6.6 GF30 black | PA6.6 GF30 black |
| Inserts, flame retardant to UL 94-V0 Polyamide PA6.6 = non-halogen | PA6.6 GF30 black | PA6.6 GF30 black | PA6.6 GF30 black | PA6.6 GF30 black | PA6.6 GF30 black | PA6.6 GF30 black |
| Seals NBR: butadiene-acrylonitrile rubber CR: chloroprene rubber | NBR, CR black | NBR, CR black | NBR, CR black | NBR, CR black | NBR, CR black | NBR, CR black |
| Contacts: crimp-type copper wrought alloy | ● | ● | ● | ● | ● | ● |
| Contact plating | Ag / Au | Ag / Au | Ag / Au | Ag / Au | Ag / Au | Ag / Au |

















Approvals



* Operating temperatures exceeding 25°C account for lower rated current values, see derating diagrams on page 20.



















** For AWG sizes refer to the conversion table on our homepage

M1 Plug

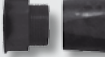
| Shell part 2 | Shell part 1 | Contact | Insert | Protection | | | |
|--|---|--|---|--|--|---|--|
|  T1-x Cable support sleeve (page 10) |  M16 Z / M16 ZB Plug with strain relief (page 8) |  SAC-x.xx-yy Pin (page 18) |  M1 E-4P+PE Pin insert (page 11) |  M1 KS / M1 K / M1 K15 Protection cap for plug (page 11) | | | |
|  M1 M20 Threaded backshell (page 9) | | | | |  M16 Plug (page 8) |  BAC-x.xx-yy Socket (page 18) |  M1 E-4S+PE Socket insert (page 11) |
|  M1 Pg13.5 / M1 M20-1, M1 M20-2 Threaded backshell M1 VPg13.5 xx / M1 VM20 xx Cable gland (page 9) | | | | |  M16 W Plug for backshell / shrink boot (page 8) |  BS-A Filler plug (page 18) |  M1 E-6P+PE Pin insert (page 11) |
|  202K142-15 Shrink boot, straight (page 10) | | | | |  M15 Flange plug (page 9) | |  M1 E-6S + PE Socket insert (page 11) |
|  222K142-15 Shrink boot, 90° (page 10) | | | | | | | |

OVERVIEW

M3 Plug

| Shell part 2 | Shell part 1 | Contact | Insert | Protection | | | |
|---|---|--|---|--|---|---|--|
|  T28-x Cable support sleeve (page 16) |  M36 Z / M3 36ZB Plug with strain relief (page 14) |  SAC-x.xx-yy Pin (page 18) |  M3 E-6P+PE Pin insert (page 17) |  M3 KS / M3 K / M3 K15 Protection cap for plug (page 16) | | | |
|  M3 Pg16 / M3 Pg21 / M3 M25 Threaded backshell (page 15) | | | | |  M36 W Plug for backshell / shrink boot (page 14) |  BAC-x.xx-yy Socket BBC-x.xx-yy Socket BCC-x.xx-yy Socket (page 18) |  M3 E-6S+PE Socket insert (page 17) |
|  M3 M25 Threaded backshell M3 VM25 11-17 Cable gland (page 15) | | | | |  M35 Flange plug (page 14) |  BS-A Filler plug BS-B Filler plug BS-C Filler plug (page 18) |  M3 E-8P+PE Pin insert (page 17) |
|  M3 Pg16 / M3 Pg21 Threaded backshell M3 VPg16 12-14 / M3 VPg21 14-18 Cable gland (page 15) | | | | | | |  M3 E-8S+PE Socket insert (page 17) |
|  202K163-15 Shrink boot, straight (page 15) | | | | | | |  M3 E-12P+PE Pin insert (page 17) |
|  222K163-15 Shrink boot, 90° (page 15) | | |  M3 E-12S+PE Socket insert (page 17) | | | | |

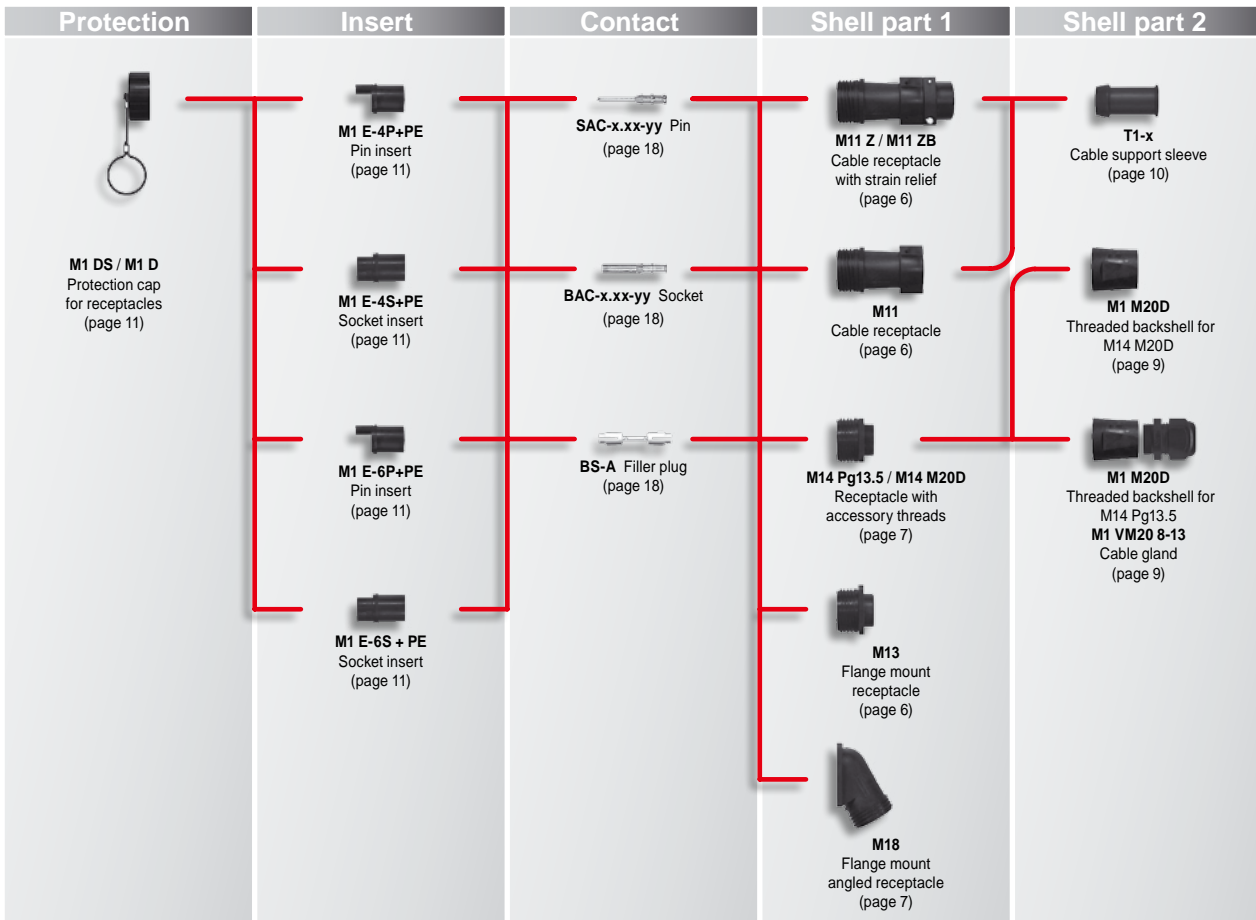

M1 Receptacle

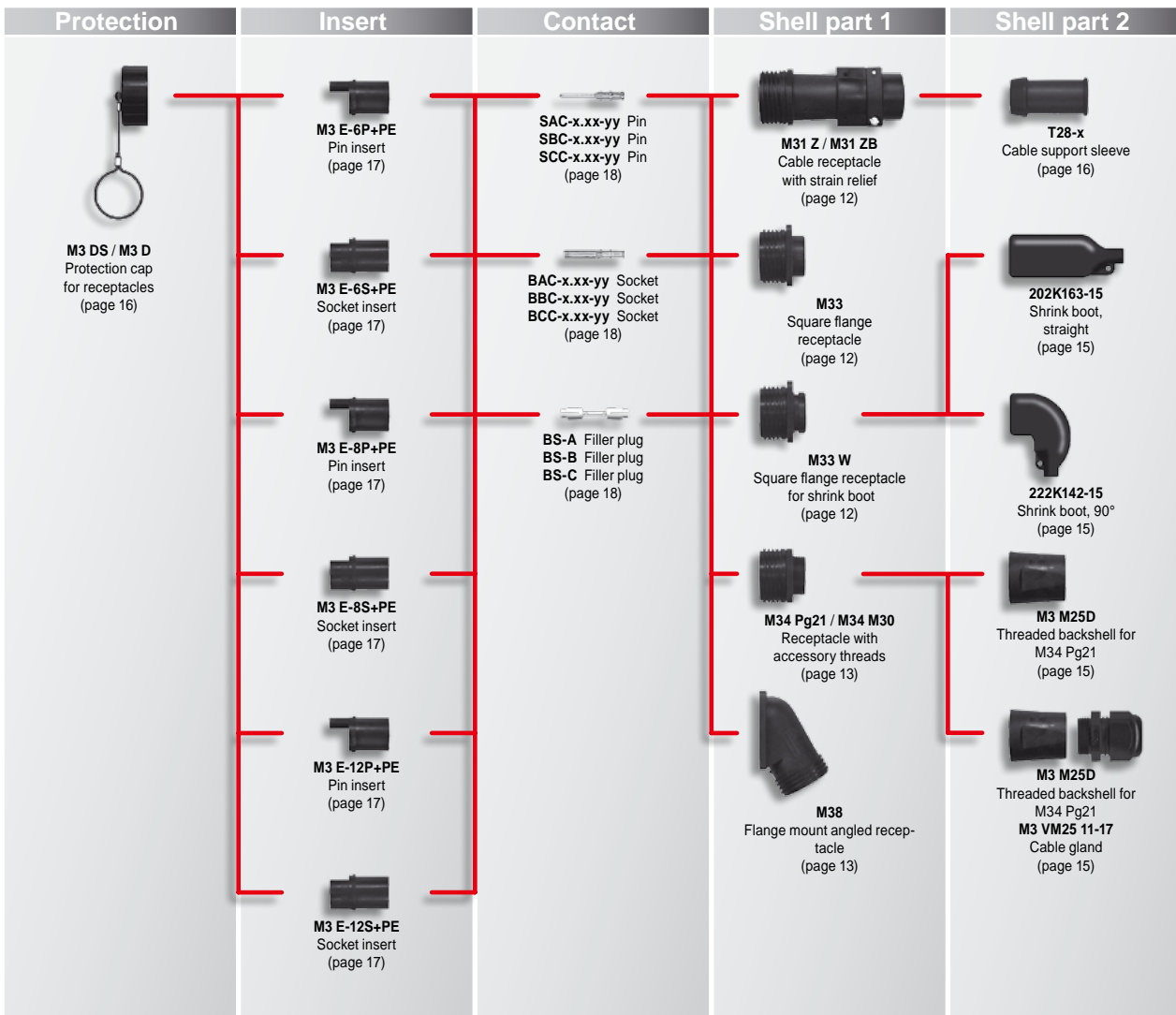

M3 Receptacle

M11 Cable receptacle

M1 series

Shell part 1

Insertion depth 13.5

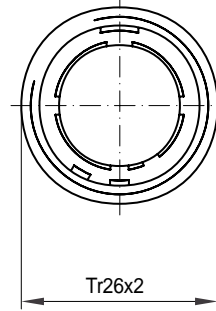
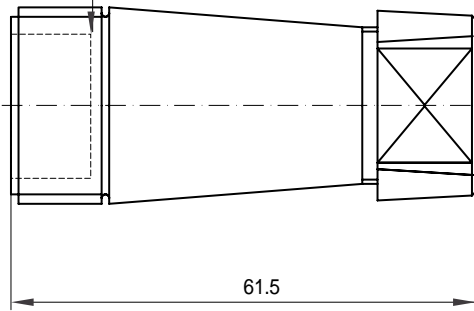

M11 Z / M11 ZB Cable receptacle with strain relief

M1 series

Shell part 1

Insertion depth 13.5

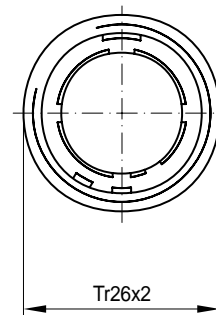
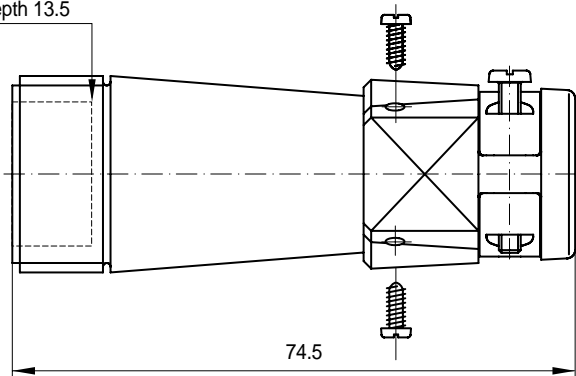

Note:

M11 ZB: All components delivered loose as kit.

To prevent the strain relief from loosening use two self-tapping cylinder head screws 2.2 x 9.5 (not included in delivery)

M13 Flange mount receptacle

M1 series

Shell part 1

Insertion depth 13.5

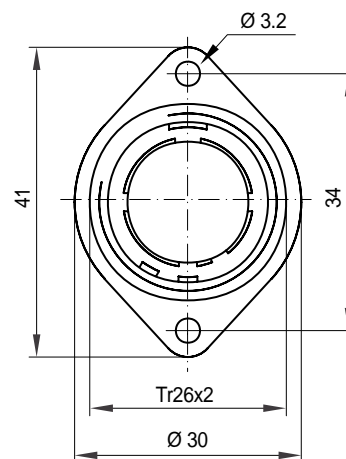
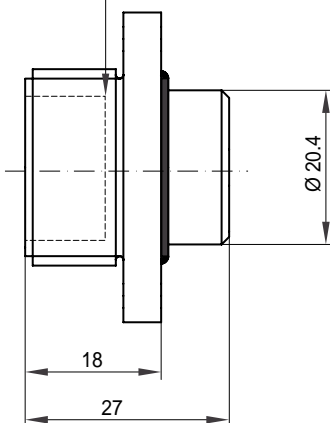

M12 M20B, M14 Pg13,5, M14 M20 Receptacle with backshell / threads

M1 series

- **M12 M20B** Receptacle with threaded backshell

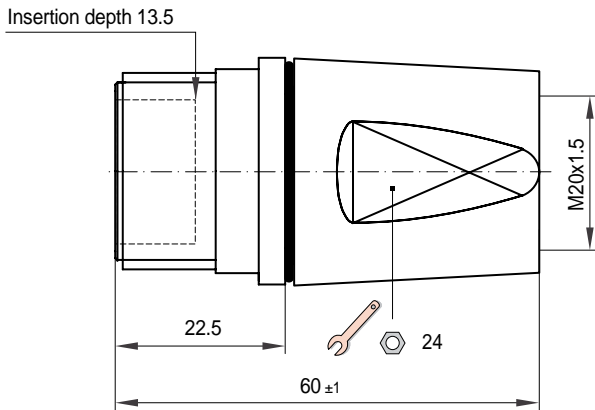

| Ordering code | Description |
|-----------------|--|
| M12 M20B | Kit comprising receptacle M14 M20 and backshell M1 M20 |

Note:

M12 M20B: Kit, components loosely packed.
 Assembly of backshell to connector: recommended tightening torque 2.5 Nm.

- **M14 Pg13.5 / M14 M20** Receptacle with threads

Shell part 1

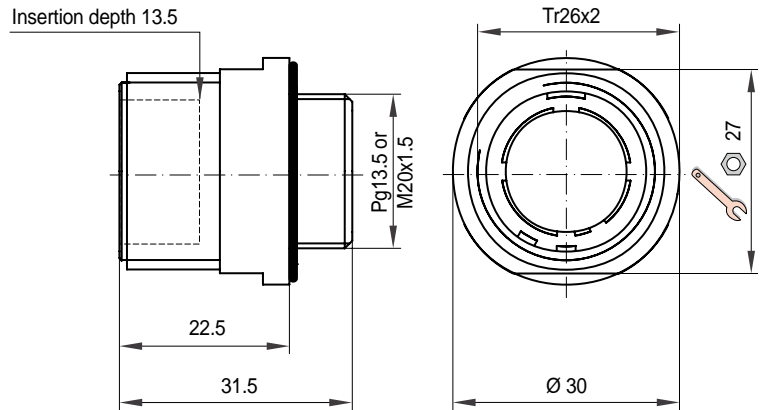

| Ordering code | Accessory threads |
|-------------------|-------------------|
| M14 Pg13.5 | Pg13.5 |
| M14 M20 | M20x1.5 |

Note:

Panel mount receptacle
 Recommended tightening torque 2.5 Nm.

M18 Flange mount angled receptacle

M1 series

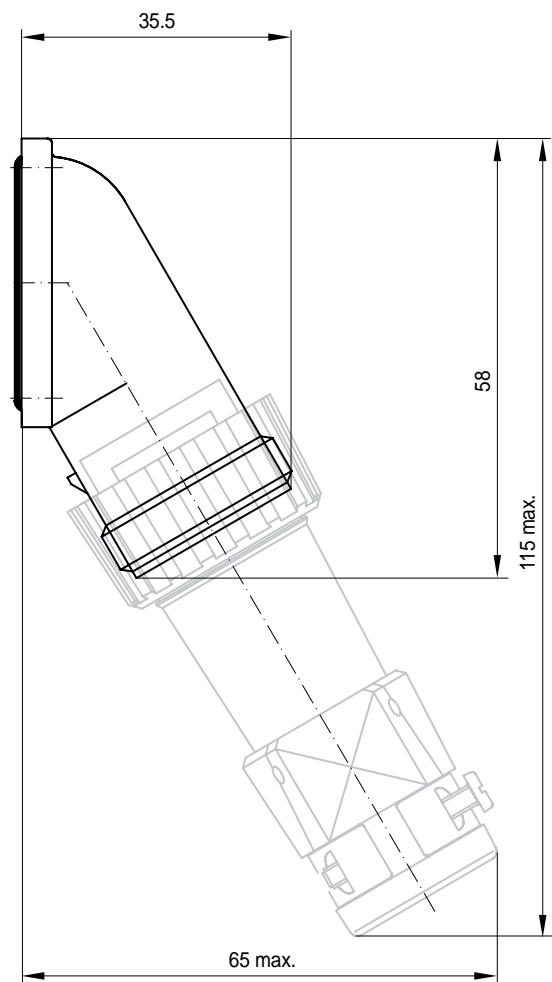
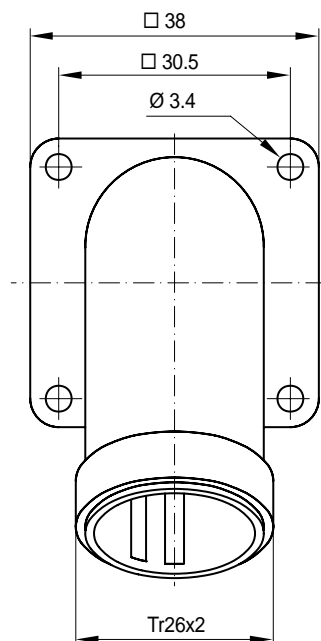

Shell part 1

M16 Plug

M1 series

Shell part 1

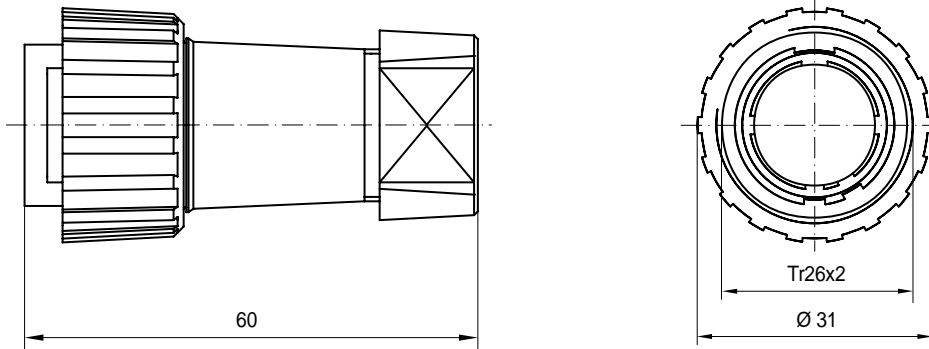

M16 Z / M16 ZB Plug with strain relief

M1 series

Shell part 1

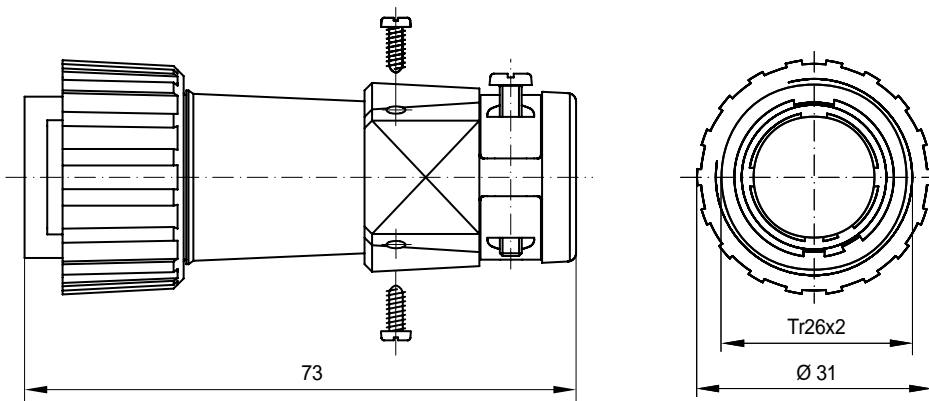

Note:

M16 ZB: Kit, all components loosely packed.

To prevent the strain relief from loosening use two self-tapping cylinder head screws 2.2 x 9.5 (not included in delivery).

M16 M20B, M16 W Plug for backshell / shrink boot

M1 series

- **M16 M20B** Plug with threaded backshell

- **M16 W** Plug with accessory threads for backshell / shrink boot

Shell part 1

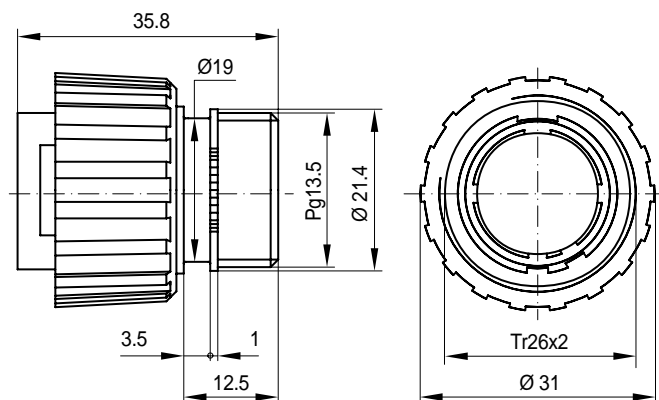
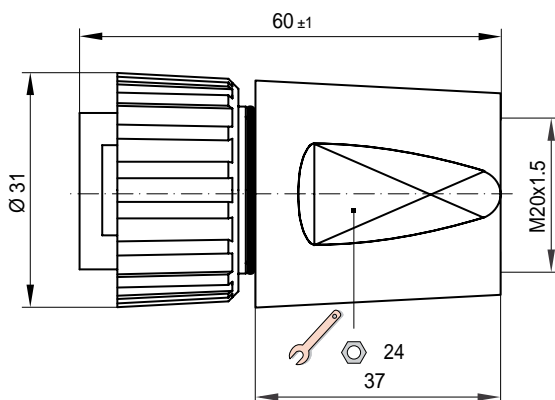

| Ordering code | Description |
|---------------|--|
| M16 M20B | Kit comprising plug M16 W and backshell M1 M20 |

Note:

M16 M20B: Kit, components loosely packed. Assembly of backshell to connector: recommended tightening torque 2.5 Nm.

M15 Flange plug M1 series

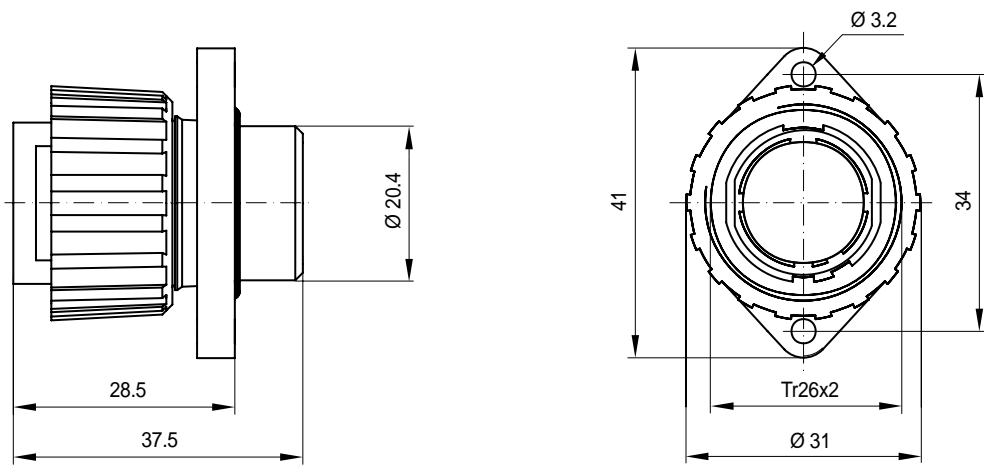

Shell part 1

M1 Pg13,5 Threaded backshell* **M1 VPg13,5 10-12 Cable gland** M1 series

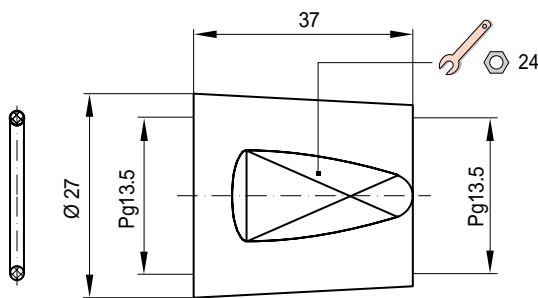

M1 Pg13.5 Backshell (sealed to IP67 up to 85°C)

| Ordering code | Accessory threads |
|---------------|-------------------|
| M1 Pg13.5 | Pg13.5 |

* For threaded backshell for Plug M16 W only

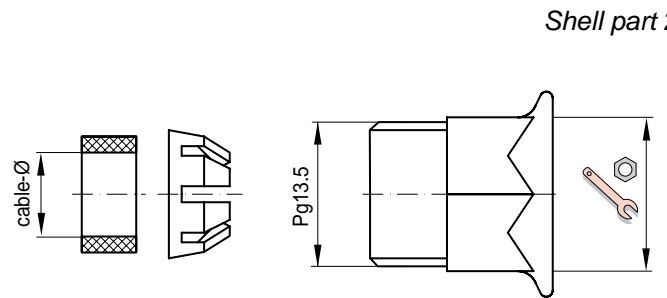

M1 VPg13.5 10-12 Gland-seal cable clamp (sealed to IP67 up to 85°C)

| Ordering code | Cable Ø | Width across flats |
|------------------|--------------|--------------------|
| M1 VPg13.5 10-12 | 10 ... 12 mm | ⊕ 22 |

Shell part 2

M1 M20, M1 M20D Threaded backshell **M1 VM20 8-13 Cable gland** M1 series

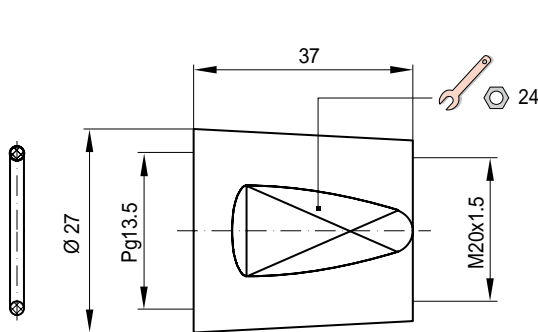

| Ordering code | Description |
|---------------|--|
| M1 M20 | Threaded backshell for Plug M16 W |
| M1 M20D | Threaded backshell for Receptacle M14 Pg13.5 |

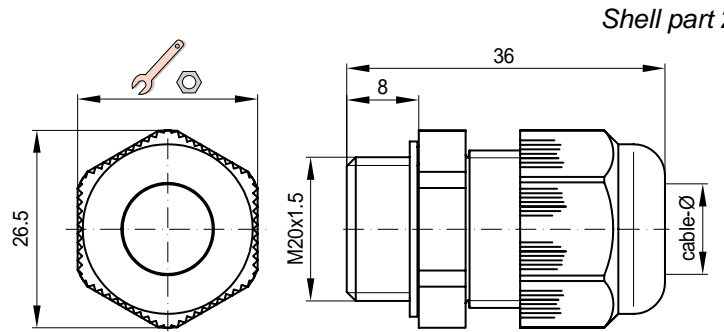

| Ordering code | Cable Ø | Width across flats |
|---------------|-------------|--------------------|
| M1 VM20 8-13 | 8 ... 13 mm | ⊕ 24 |

Further cable-Ø upon request

Shell part 2

222K142-15, 202K142-15 Shrink boot

M1 series

Shell part 2

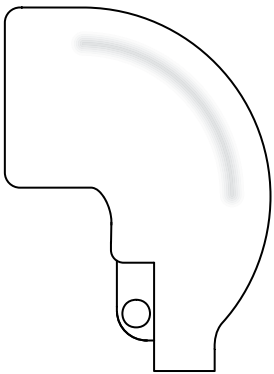

Shrink boot, 90°, **222K142-15**

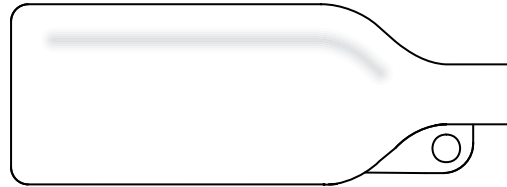

Shrink boot, straight, **202K142-15**

T1-x Cable support sleeve, Seal ring

M1 series

Shell part 2

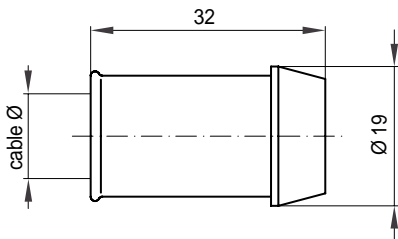

Figure A: **Cable support sleeve**

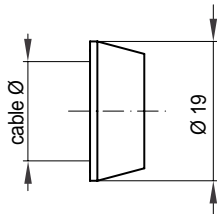

Figure B: **Seal ring**

| Ordering code | Cable diameter [mm] | Figure |
|---------------|---------------------|--------|
| T1-4/6 | 4 - 6 | Fig. A |
| T1-6/8 | 6 - 8 | Fig. A |
| T1-8/10 | 8 - 10 | Fig. A |
| T1-10/12 | 10 - 12 | Fig. A |
| T1-12/13 | 12 - 13 | Fig. A |
| T1-14.5 | 14 - 15 | Fig. B |

VW-M1 E-x Insertion tools for M1 inserts

M1 series

Tools

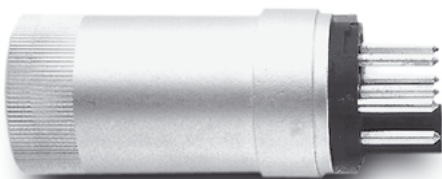

Insertion tool

VW-M1 E-4S for socket insert M1 E-4S+PE
VW-M1 E-6S for socket insert M1 E-6S+PE

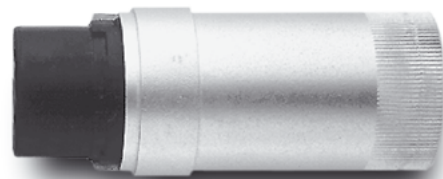

Insertion tool

VW-M1 E-4P for pin insert M1 E-4P+PE
VW-M1 E-6P for pin insert M1 E-6P+PE

M1 KS, M1 K, M1 K15, M1 DS, M1 D Protection cap

M1 series

Protection cap for plug

Protection cap for receptacle

Shell part 2

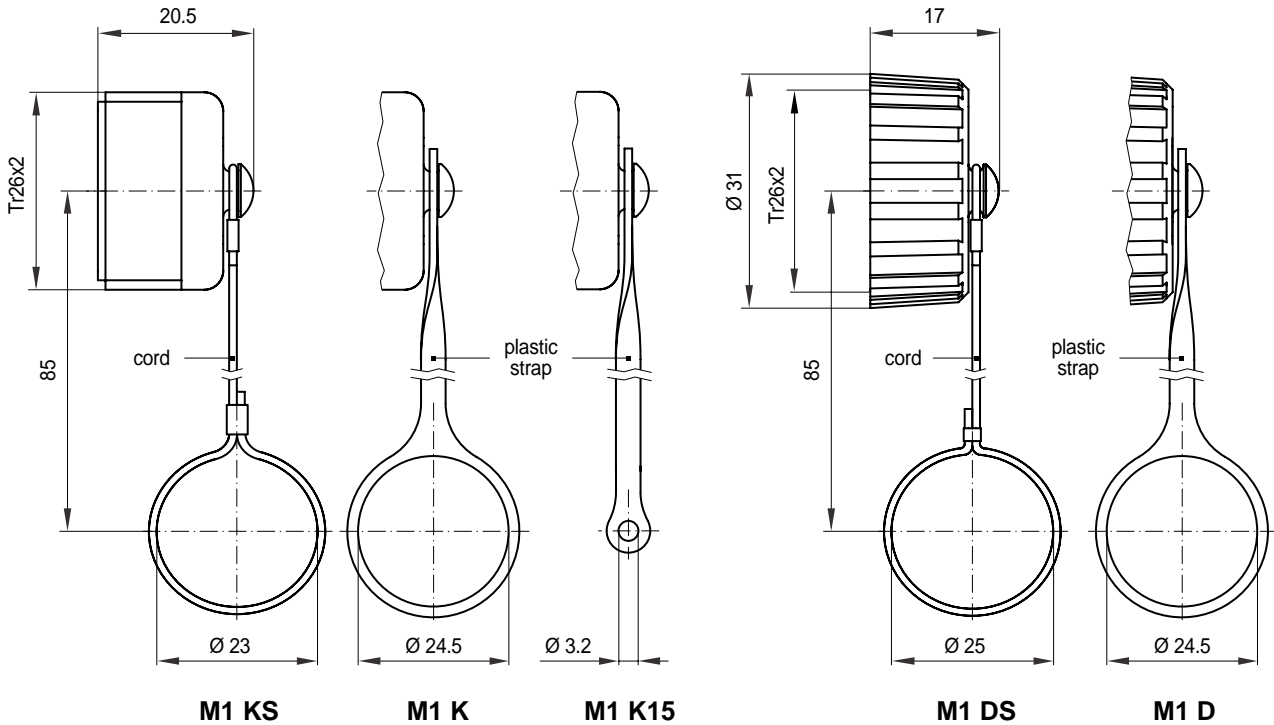

M1 E-4P+PE, M1 E-6P+PE Pin insert 4 and 6 pole + PE

M1 E-4S+PE, M1 E-6S+PE Socket insert 4 and 6 pole + PE

M1 series

Inserts

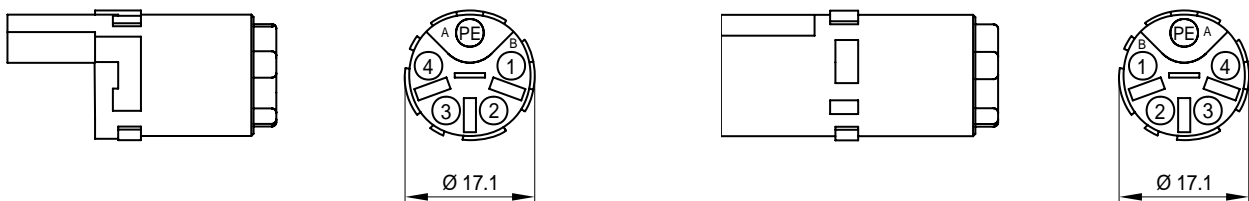

Pin insert **M1 E-4P+PE**

Socket insert **M1 E-4S+PE**

| Layout | M1 Series | |
|---|---------------|-----------|
| | 4 + PE | 6 + PE |
| Number of contacts | 4 + PE | 6 + PE |
| Contact arrangement | | |
| Contact identification marked on insert: | | |
| Pin insert: Rear view | | |
| Socket insert: Front view | | |
| Rated voltage (IEC 60038) at pollution degree 3 (IEC 60512) | 230 V / 400 V | 250 V |
| Key positions | 2 | 2 |
| Contacts | | |
| Max. rated current of individual contact | 4x 16 A | 6x 16 A |
| Contact diameter | Ø 1.58 mm | Ø 1.58 mm |
| Contact type | Type A | Type A |

M31 Z, M31 ZB Cable receptacle with strain relief

M3 series

Shell part 1

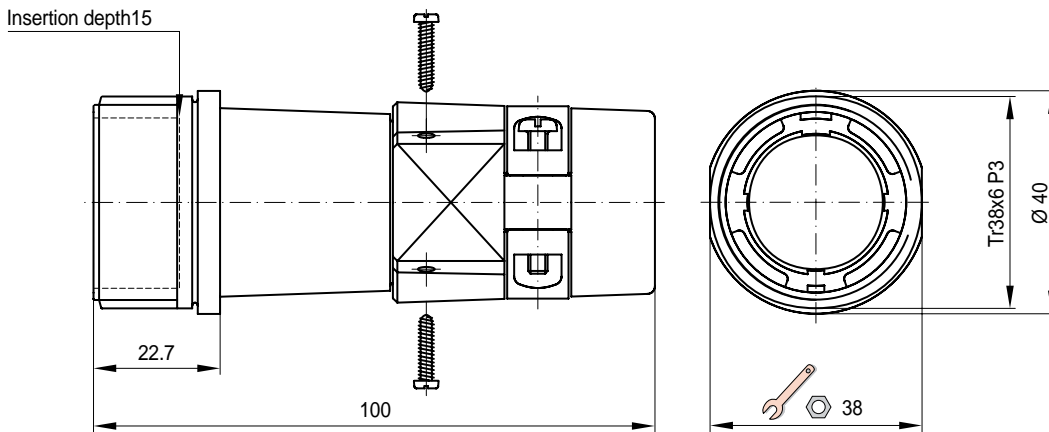

Note:

M31 ZB: Kit, all components loosely packed.

To prevent the strain relief from loosening use two self-tapping cylinder head screws 2.9 x 13 (not included in delivery).

M33 Square flange receptacle

M3 series

Shell part 1

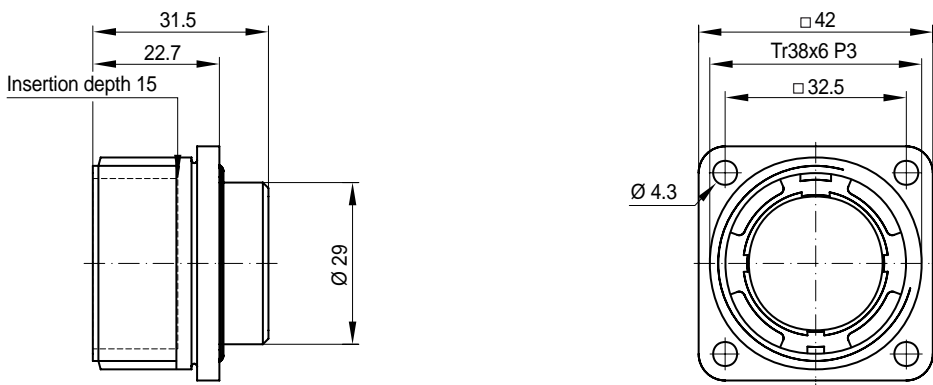

M33 W Square flange receptacle for shrink boot

M3 series

Shell part 1

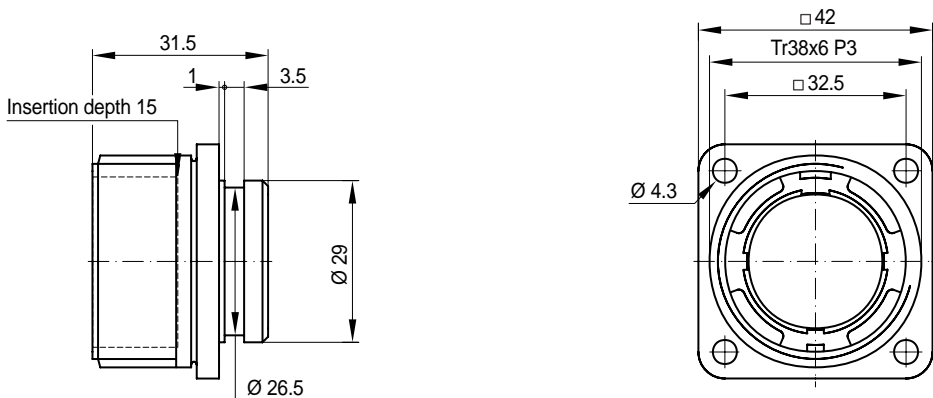

M32 M25B, M34 Pg21, M34 M30 Receptacle with backshell / threads

M3 series

- **M32 M25B** Receptacle with threaded backshell

- **M34 Pg21 / M34 M30** Receptacle with threads

Shell part 1

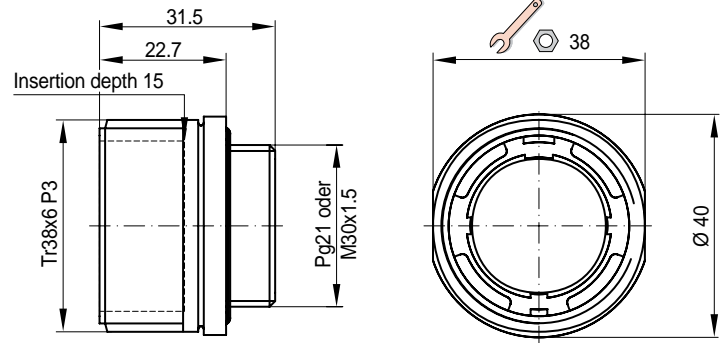
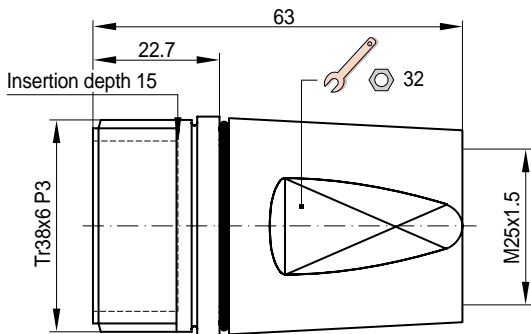

| Ordering code | Description |
|---------------|--|
| M32 M25B | Kit comprising receptacle M34 Pg21 and backshell M3 M25D |

Note:
M32 M25B: Kit, components loosely packed.
 Assembly of backshell to connector: recommended tightening torque 2.5 Nm.

| Ordering code | Accessory threads |
|---------------|-------------------|
| M34 Pg21 | Pg21 |
| M34 M30 | M30x1.5 |

Note:
 Panel mount receptacle
 Recommended tightening torque 2.5 Nm.

M38 Flange mount angled receptacle

M3 series

Shell part 1

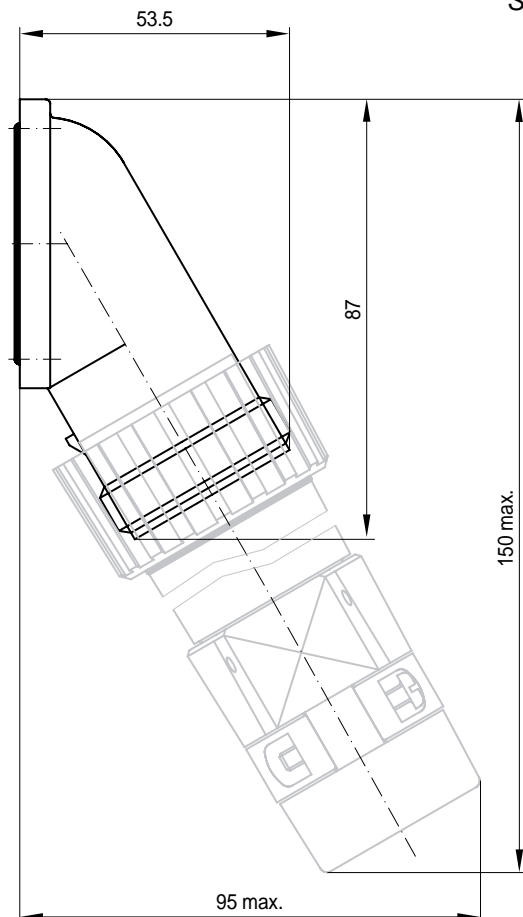
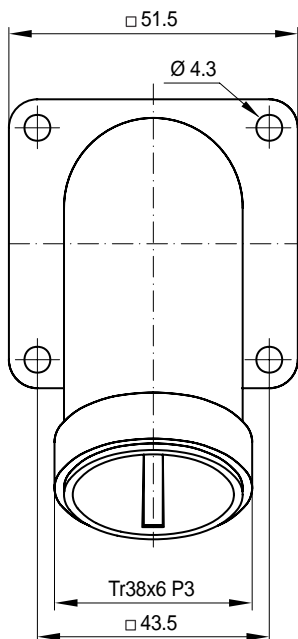

M36 Z, M36 ZB Plug with strain relief

M3 series

Shell part 1

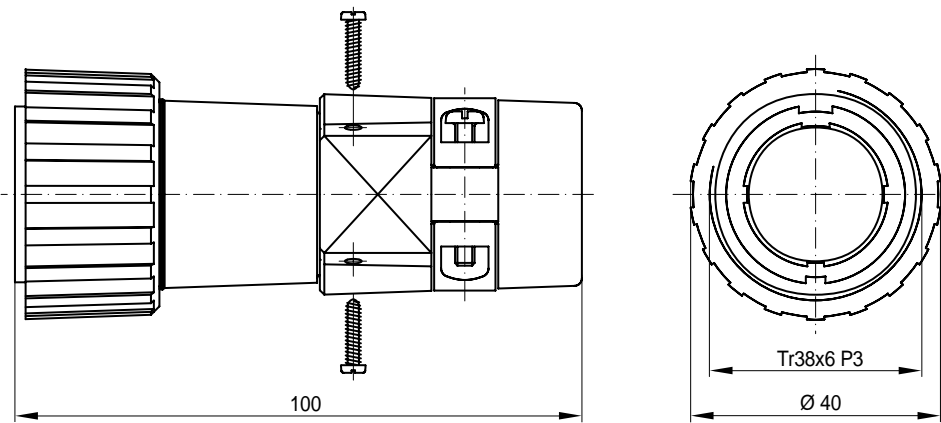

Note:

M36 ZB: Kit, all components loosely packed.

To prevent the strain relief from loosening use two self-tapping cylinder head screws 2.9 x 13 (not included in delivery).

M36 W Plug for backshell / shrink boot

M3 series

Shell part 1

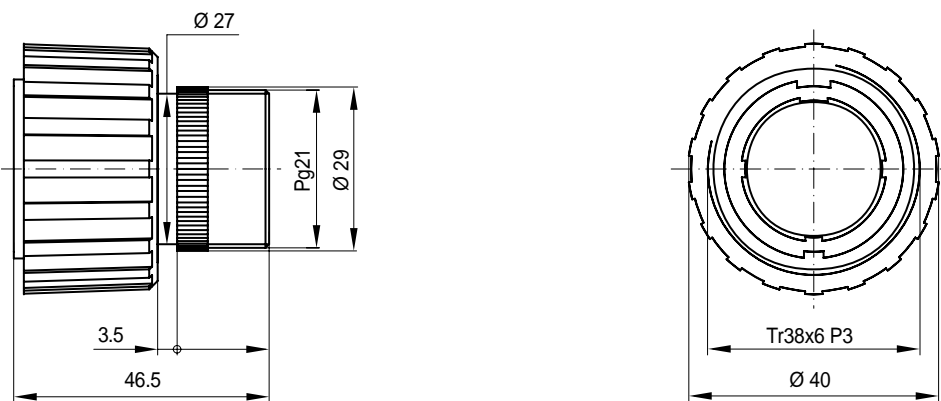

M35 Square flange plug

M3 series

Shell part 1

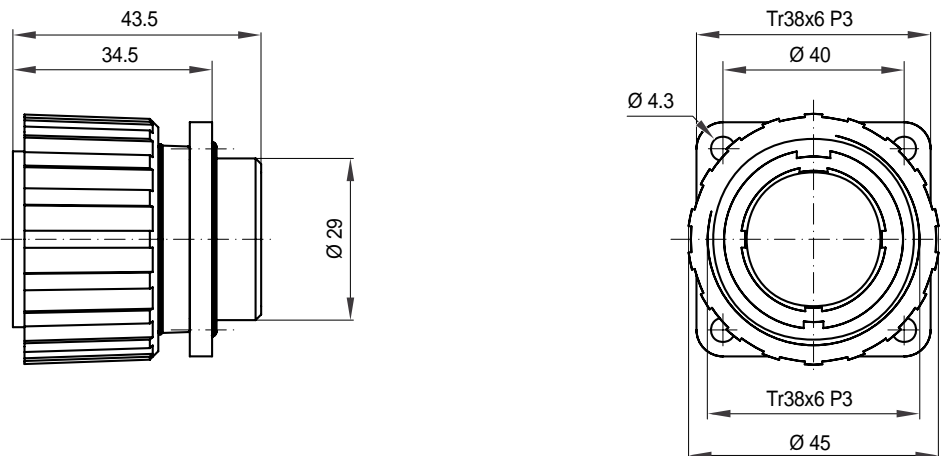

M3 Pg16, M3 Pg21 Threaded backshell * **M3 VPg21 xx Cable gland** M3 series

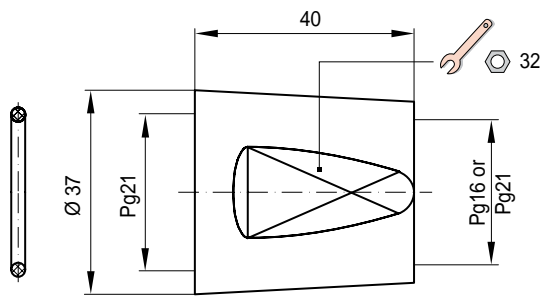

M3 Pg21 Backshell (sealed to IP67 up to 85°C)

| Ordering code | Threads | |
|----------------|---------|------|
| | front | rear |
| M3 Pg16 | Pg21 | Pg16 |
| M3 Pg21 | Pg21 | Pg21 |

* For threaded backshell for Plug M36 W only

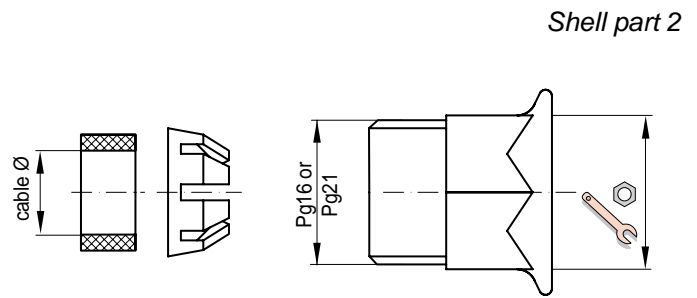

M3 VPg21 14-18 Gland-seal cable clamp (sealed to IP67 up to 85°C)

| Ordering code | Thread | Cable Ø | Width across flats |
|-----------------------|--------|--------------|--------------------|
| M3 VPg16 12-14 | Pg16 | 12 ... 14 mm | ⊙ 24 |
| M3 VPg21 14-18 | Pg21 | 14 ... 18 mm | ⊙ 30 |

M3 M25, M3 M25D Threaded backshell **M3 VM25 11-17 Cable gland** M3 series

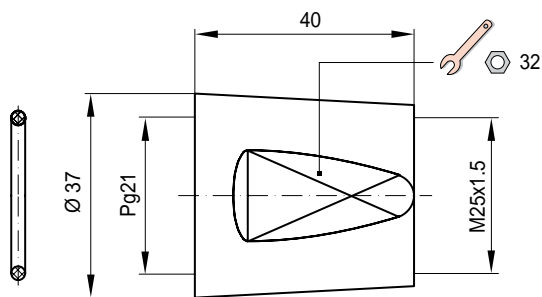

| Ordering code | Description |
|----------------|--|
| M3 M25 | Threaded backshell for Plug M36 W |
| M3 M25D | Threaded backshell for Receptacle M34 Pg21 |

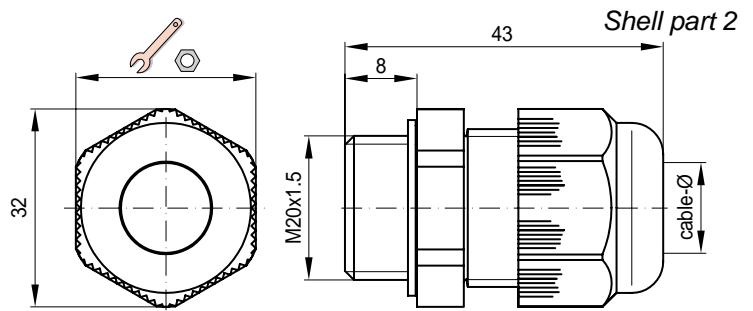

| Ordering code | Cable Ø | Width across flats |
|----------------------|--------------|--------------------|
| M3 VM25 11-17 | 11 ... 17 mm | ⊙ 29 |

Further cable-Ø upon request

222K163-15, 202K163-15 Shrink boot M3 series

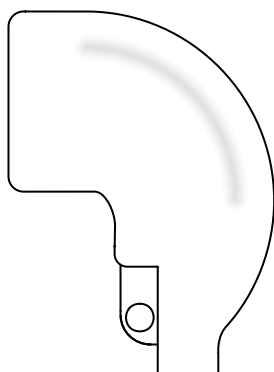

Shrink boot, 90° **222K163-15**



Shrink boot, straight, **202K163-15**

Shell part 2

M3 KS, M3 K, M3 K35, M3 DS, M3 D Protection cap

M3 series

Protection cap for plug

Protection cap for receptacle

Shell part 2

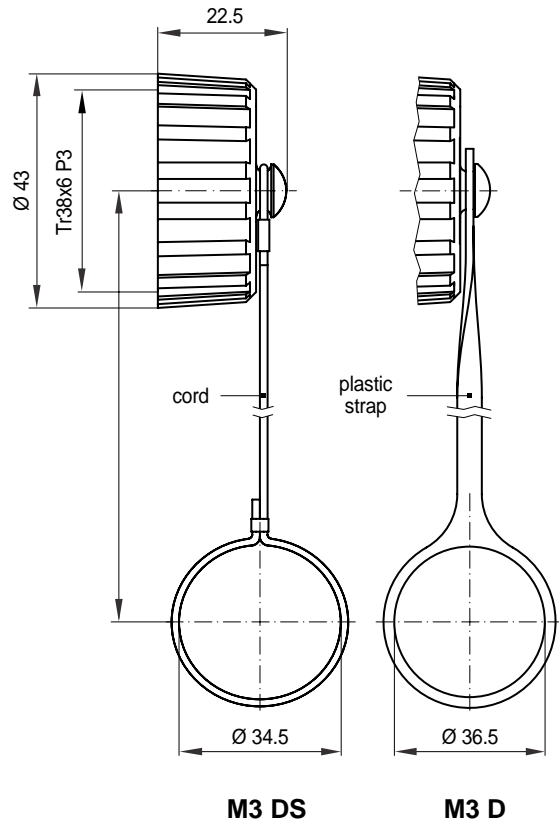
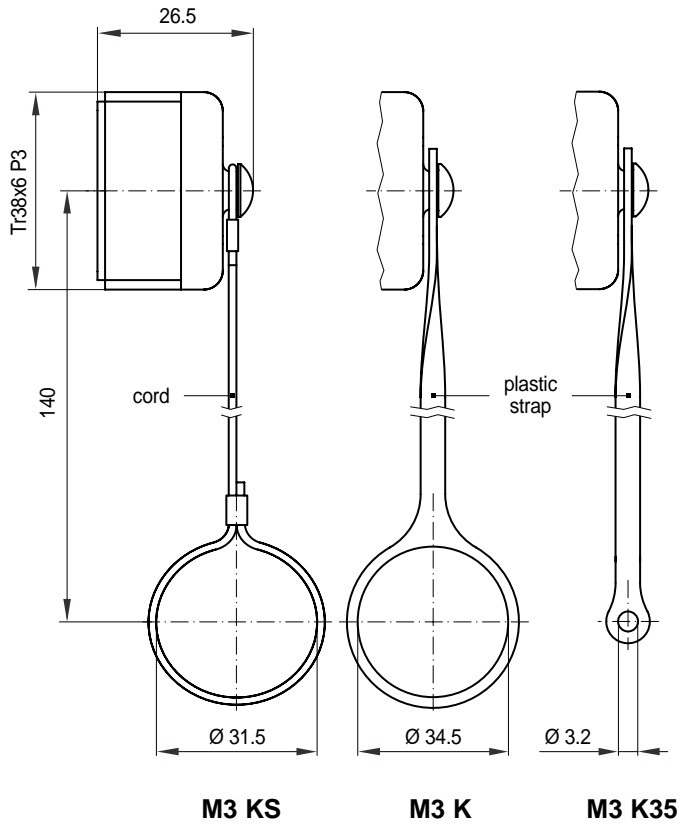

T-28-x Cable support sleeve

M3 series

Shell part 2

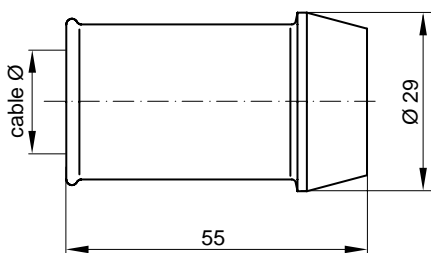

| Ordering code | Cable diameter [mm] |
|---------------|---------------------|
| T28-10/13 | 10 - 13 |
| T28-13/16 | 13 - 16 |
| T28-16/18.5 | 16 - 18,5 |
| T28-18.5/20.5 | 18.5 - 20,5 |
| T28-20.5/22 | 20.5 - 22 |

M3 E-6/8/12P+PE Pin insert 6, 8 and 12 pole + PE

M3 E-6/8/12S+PE Socket insert 6, 8 and 12 pole + PE

M3 series

Inserts

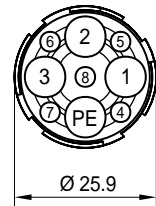
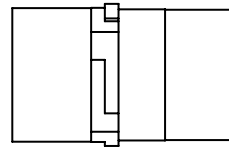
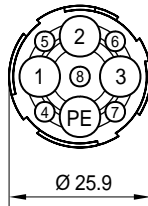
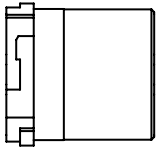
Pin insert **M3 E-8P+PE**Socket insert **M3 E-8S+PE**

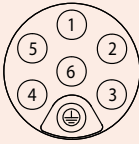
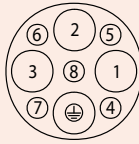
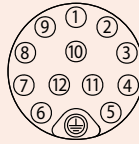
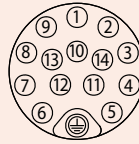
| Layout | M3 Series | | | |
|--|---|--|---|---|
| | 6 + PE | 8 + PE | 12 + PE | 7+7 + PE |
| Number of contacts | | | | |
| Contact arrangement Contact identification marked on insert: Pin insert: Front view Socket insert: Rear view |  |  |  |  |
| Rated voltage (IEC 60038) at pollution degree 3 (IEC 60512) Contact cavity | 230 V / 400 V 1 ... 6 | 230 V / 400 V 25 V 1 ... 3 4 ... 8 | 250 V 1 ... 12 | 250 V 200 V 1,2,4,5,6,7,9 3,8,10 ... 14 |
| Key positions | 2 | 1 | 2 | 2 |
| Contacts Max. rated current of individual contacts Contact diameter Contact type | 6x 32 A Ø 2.30 mm Type B | 3x 50 A 5x 16 A Ø 4.0 mm Ø 1.58 mm Type C Type A | 12x 16 A Ø 1.58 mm Type A | 14x 16 A Ø 1.8 mm Type A |

VW-M3 E-x Insertion tools for M3 inserts

M3 series

Tools

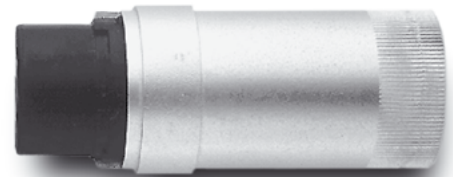

Insertion tool

- VW-M3 E-6S** for socket insert M3 E-6S+PE
- VW-M3 E-8S** for socket insert M3 E-8S+PE
- VW-M3 E-12S** for socket insert M3 E-12S+PE

Insertion tool

- VW-M3 E-6P** for pin insert M3 E-6P+PE
- VW-M3 E-8P** for pin insert M3 E-8P+PE
- VW-M3 E-12P** for pin insert M3 E-12P+PE

Ordering code contacts

Contacts

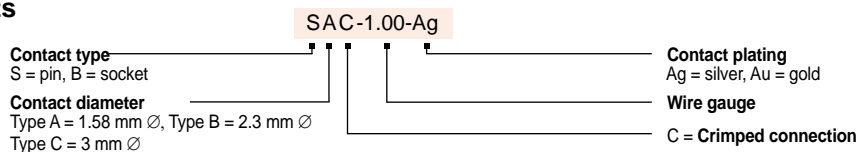
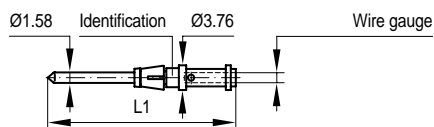
Contacts SAC-x, BAC-x, BS-A Crimp contacts (pin/socket) and filler plug:

Pin contacts, silver plated

| Ordering code | L1 | Identification |
|---------------|------|----------------|
| SAC-0.50-Ag | 28.6 | No grooves |
| SAC-1.00-Ag | 28.6 | 1 groove |
| SAC-1.50-Ag | 28.6 | 2 grooves |
| SAC-2.50-Ag | 28.6 | 3 grooves |

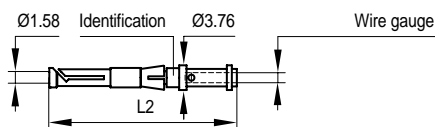

Socket contacts, silver plated

| Ordering code | L2 | Identification |
|---------------|------|----------------|
| BAC-0.50-Ag | 28.6 | No grooves |
| BAC-1.00-Ag | 28.6 | 1 groove |
| BAC-1.50-Ag | 28.6 | 2 grooves |
| BAC-2.50-Ag | 28.6 | 3 grooves |

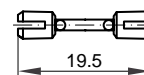

Filler plug:

BS-A: Empty cavities can be fitted with filler plugs

Specifications

| Cross-sectional area* | Rated current |
|--|---------------|
| 0.5 mm ² | 7.5 A |
| 0.75 mm ² ... 1 mm ² | 10 A |
| 1.5 mm ² | 16 A |
| 2.5 mm ² | 16 A |

Pin contacts, gold plated

| Ordering code | L1 | Identification |
|---------------|------|----------------|
| SAC-0.50-Au | 28.6 | No grooves |
| SAC-1.00-Au | 28.6 | 1 groove |
| SAC-1.50-Au | 28.6 | 2 grooves |
| SAC-2.50-Au | 28.6 | 3 grooves |

Socket contacts, gold plated

| Ordering code | L2 | Identification |
|---------------|------|----------------|
| BAC-0.50-Au | 28.6 | No grooves |
| BAC-1.00-Au | 28.6 | 1 groove |
| BAC-1.50-Au | 28.6 | 2 grooves |
| BAC-2.50-Au | 28.6 | 3 grooves |

Specifications

| Cross-sectional area* | Rated current |
|--|---------------|
| 0.5 mm ² | 7.5 A |
| 0.75 mm ² ... 1 mm ² | 10 A |
| 1.5 mm ² | 16 A |
| 2.5 mm ² | 16 A |

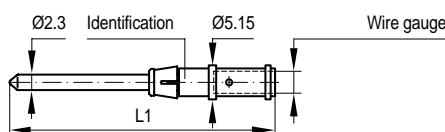
Contacts SBC-x, BBC-x, BS-B Crimp contacts (pin/socket) and filler plugs:

Pin contacts, silver plated

| Ordering code | L1 | Identification |
|---------------|------|----------------|
| SBC-0.50-Ag | 40.4 | No grooves |
| SBC-1.00-Ag | 40.4 | 1 groove |
| SBC-1.50-Ag | 40.4 | 2 grooves |
| SBC-2.50-Ag | 39.0 | 3 grooves |
| SBC-4.00-Ag | 39.0 | 1 wide groove |
| SBC-6.00-Ag | 39.0 | 2 wide grooves |

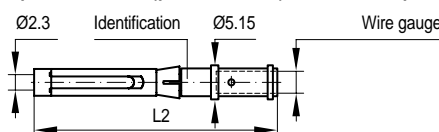

Socket contacts, silver plated

| Ordering code | L2 | Identification |
|---------------|------|----------------|
| BBC-0.50-Ag | 37.0 | No grooves |
| BBC-1.00-Ag | 37.0 | 1 groove |
| BBC-1.50-Ag | 37.0 | 2 grooves |
| BBC-2.50-Ag | 35.6 | 3 grooves |
| BBC-4.00-Ag | 35.6 | 1 wide groove |
| BBC-6.00-Ag | 35.6 | 2 wide grooves |

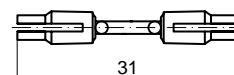

Filler plugs:

BS-B: Empty cavities can be fitted with filler plugs

Specifications

| Cross-sectional area* | Rated current |
|-----------------------|---------------|
| 0.5 mm ² | 7.5 A |
| 1.0 mm ² | 10 A |
| 1.5 mm ² | 16 A |
| 2.5 mm ² | 27.5 A |
| 4 mm ² | 35 A |
| 6 mm ² | 35 A |

Pin contacts, gold plated

| Ordering code | L1 | Identification |
|---------------|------|----------------|
| SBC-0.50-Ag | 40.4 | No grooves |
| SBC-1.00-Ag | 40.4 | 1 groove |
| SBC-1.50-Au | 40.4 | 2 grooves |
| SBC-2.50-Au | 39.0 | 3 grooves |
| SBC-4.00-Au | 39.0 | 1 wide groove |
| SBC-6.00-Ag | 39.0 | 2 wide grooves |

Socket contacts, gold plated

| Ordering code | L2 | Identification |
|---------------|------|----------------|
| BBC-0.50-Ag | 37.0 | No grooves |
| BBC-1.00-Ag | 37.0 | 1 groove |
| BBC-1.50-Au | 37.0 | 2 grooves |
| BBC-2.50-Au | 35.6 | 3 grooves |
| BBC-4.00-Au | 35.6 | 1 wide groove |
| BBC-6.00-Ag | 35.6 | 2 wide grooves |

Specifications

| Cross-sectional area* | Rated current |
|-----------------------|---------------|
| 0.5 mm ² | 7.5 A |
| 1.0 mm ² | 10 A |
| 1.5 mm ² | 16 A |
| 2.5 mm ² | 27.5 A |
| 4 mm ² | 35 A |
| 6 mm ² | 35 A |

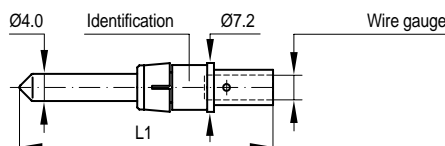
Contacts SCC-x, BCC-x, BS-C Crimp contacts (pin/socket) and filler plugs:

Pin contacts, silver plated

| Ordering code | L1 | Identification |
|---------------|------|----------------|
| SCC-2.50-Ag | 37,5 | 3 grooves |
| SCC-4.00-Ag | 37,5 | 1 wide groove |
| SCC-6.00-Ag | 37,5 | 2 wide grooves |

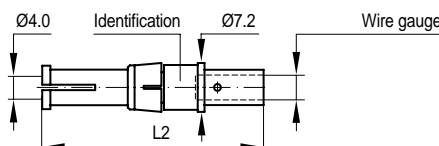

Socket contacts, silver plated

| Ordering code | L2 | Identification |
|---------------|------|----------------|
| BCC-2.50-Ag | 32,6 | 3 grooves |
| BCC-4.00-Ag | 32,6 | 1 wide groove |
| BCC-6.00-Ag | 32,6 | 2 wide grooves |

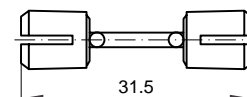

Filler plugs:

BS-C: Empty cavities can be fitted with filler plugs

Specifications

| Cross-sectional area* | Rated current |
|-----------------------|---------------|
| 2.5 mm ² | 27.5 A |
| 4 mm ² | 35 A |
| 6 mm ² | 50 A |

Note: PE (protection earth) contacts must be of the same AWG size as the main contacts

Schaltbau recommends CuSn conductors (tinned) when using the connectors

- under extreme ambient air temperatures of +60°C ... +100°C and -25°C ... 0°C respectively
- or under conditions of extreme fluctuation of temperature and humidity.

Filler plugs:

- Fill the empty cavities with filler plugs from the mating face
- Cavities of pin inserts can only be filled with half a filler plug

* For AWG sizes refer to

Derating diagrams

M1, M3 series

● **Derating curve M1 E4P+PE and M1 E4S+PE**

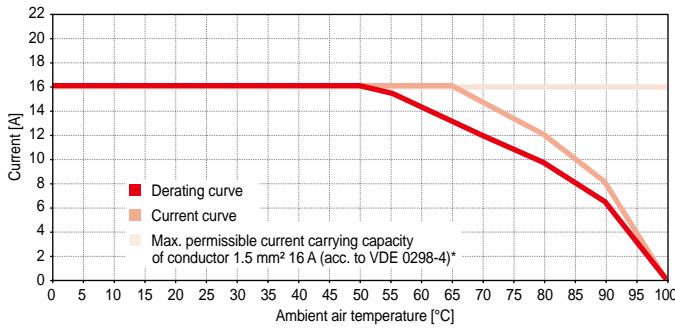

● **Derating curve M1 E6P+PE and M1 E6S+PE**

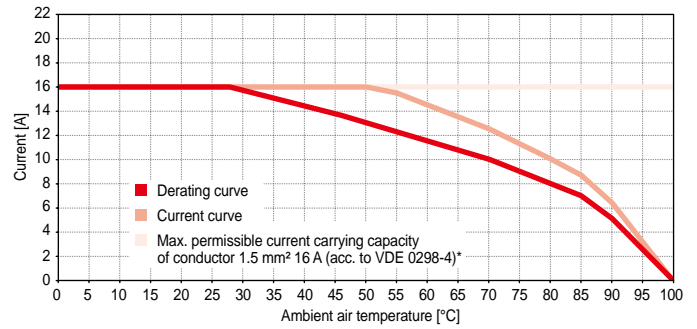

● **Derating curve M3 E6P+PE and M3 E6S+PE**

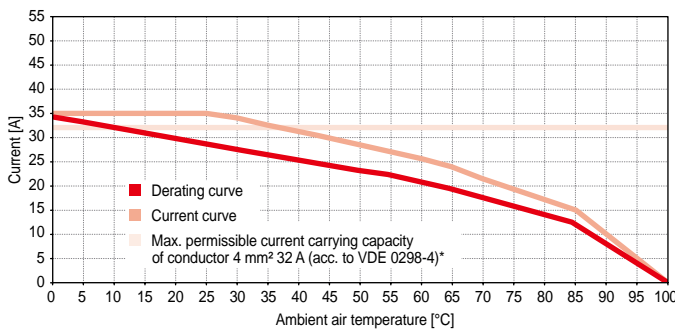

● **Derating curve M3 E8P+PE and M3 E8S+PE**

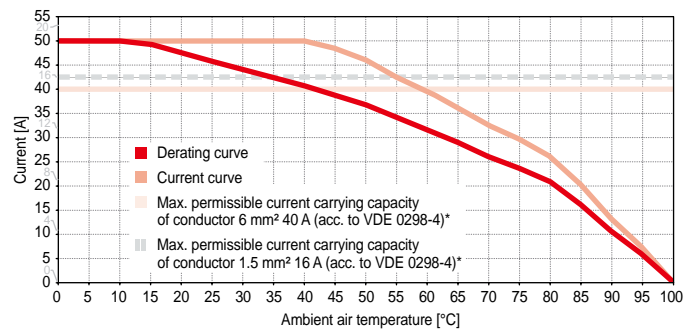

● **Derating curve M3 E12P+PE and M3 E12S+PE**

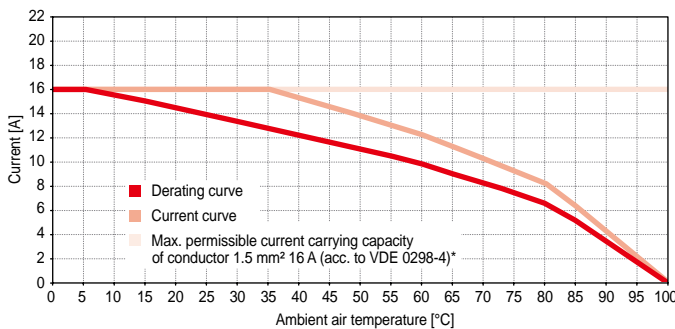

Notes:

- According to VDE 0298-4 the wire gauge of the conductor should be determined in this way that within the limits of its specified current carrying capacity there will be no heating of the conductor exceeding the permissible operating temperature at any place or at any time.
- The derating diagrams show the permissible operating range.
- Control and test procedures according to IEC 60512-3, test 5b.

AWZ-x Extraction tool

CWZ-600 Crimp tool

M1, M3 series

Tools

Tools



(Figure reduced)

- AWZ-A:** Extraction tool for contacts Type A
- AWZ-B:** Extraction tool for contacts Type B
- AWZ-C/H:** Extraction tool for contacts Type C/H

CWZ-600: Crimp tool for wire gauges* ranging from 0.14 mm² to 6 mm²

* For AWG sizes refer to

● Assembly of plugs

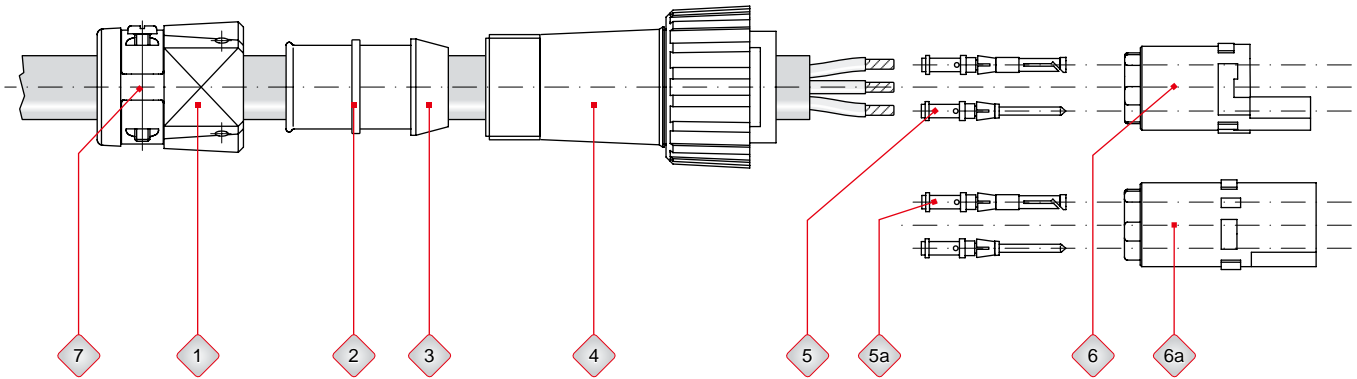

Fig.: Assembly of plugs M16 Z or M36 Z (also applies to cable receptacles M11 Z or M31 Z correspondingly)

Parts 1, 2, 3 and 4 to be threaded on cable.

Trim the individual cables to the desired length and strip the insulation to a length of 7 mm.

Crimp wires to contacts (5 or 5a). Wire insulation is to be extended to the point of crimping. As protective earth contact (PE) a socket contact is used with pin inserts and a pin contact

with socket inserts except for inserts M3 E-8P+PE and M3 E-8S+PE where all contacts are of the same kind.

Fit crimped contacts (5 or 5a) into contact insert (6 or 6a). Make sure that clip is locked in place in contact insert.

We recommend checking of the established contact: The contact retention test force is 40 N.

● Assembly of receptacles

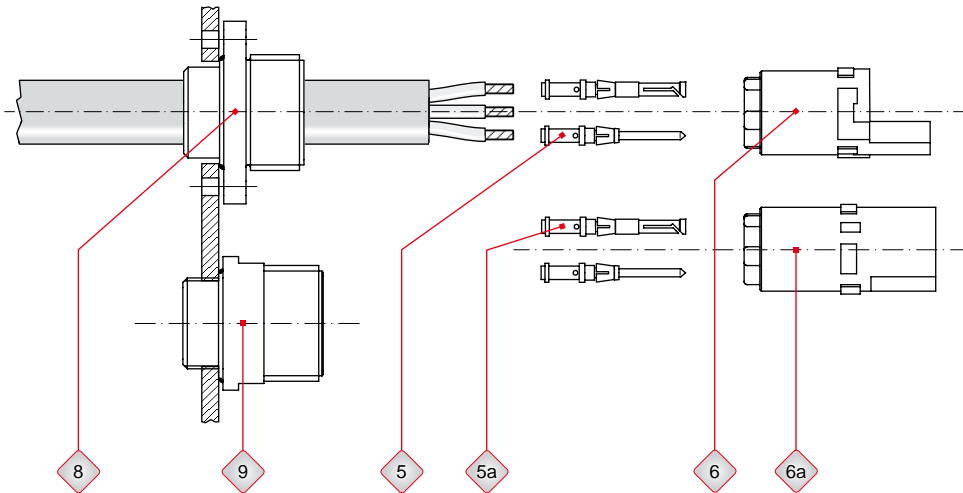

Fig.: Assembly of receptacles M13, M14 Pg13,5 or M14 M20, M18, M33, M33 W, M34 Pg21 or M34 M30, M38

Mount receptacle with flange (8) on to wall with prefabricated mounting holes (see Mounting holes).

Screw receptacle with threaded joint (9) into mounting wall with corresponding thread.

Assembly of contacts and contact inserts is the same as for plugs.

Disassembly is carried out the other way round.

● Disassembly of connectors

Disassemble the strain relief cable clamp (parts 7, 1, 2 and 3).

Unlock contact insert (6 or 6a) within the shell by turning the insert 45° counter-clockwise using our recommended insertion tool. Pull insert out of the shell (4).

Feed extraction tool (see p. 18) in hole of contact insert.

Assembly instructions (continued)

M1, M3 series

● **Assembly of contact inserts**

Fit contact insert (6 or 6a) into shell (4). Ensure positioning is correct. Press contact insert against the spring within the shell and lock into position by turning 45° clockwise. We recommend the use of our insertion tool (see p. 11 and 16 respectively) for assembly. Contact inserts can be mounted in two different positions. Press part 2 and 3 into part 4 to assemble the strain relief

clamp and screw part 1 tightly onto part 4. The recommended tightening torque is 1-2 Nm. Finally screw the clamping bars (part 7) into position in the strain relief cable clamp. Finally screw the clamping bars into position in the strain relief cable clamp. To prevent the strain relief from loosening use two self-tapping cylinder head screws (see p. 6, 8 and 12, 14 respectively).

Key position 1:

Is shown in a mounting position towards the wide bridge of the shell (normal position, no insert rotation)

Key position 2:

Insert is rotated in its shell from a normal position at an angle of 90°

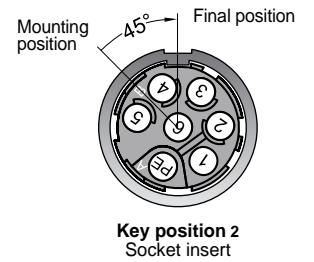
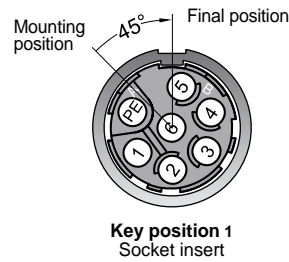

Mounting holes

M1, M3 series

● **Flange mount receptacles and plugs**

● **Flange mount angled receptacles**

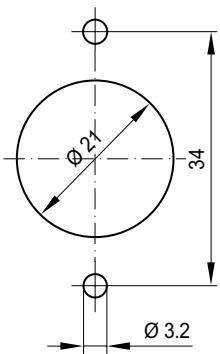

M13, M15

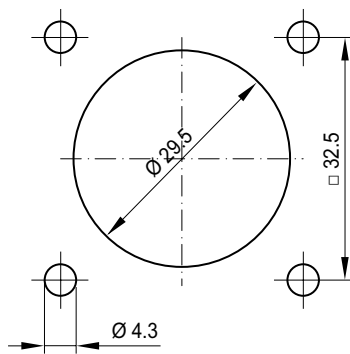

M33, M33 W, M35

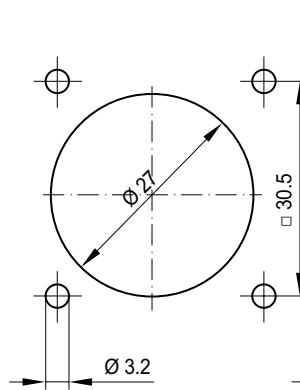

M18

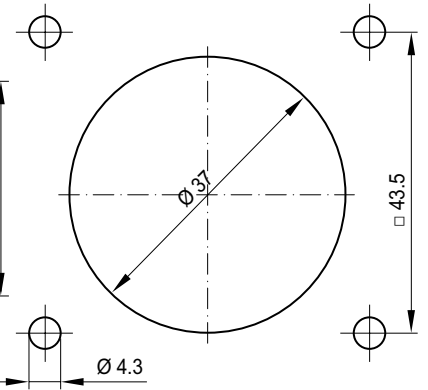

M38

● **Receptacles with accessory threads**

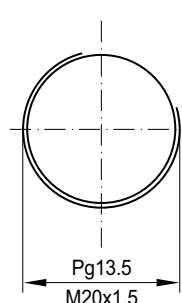

M14

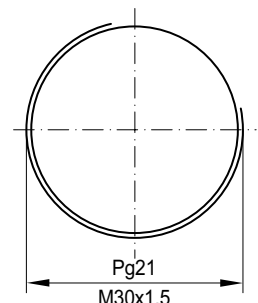

M34

How to order











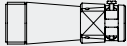

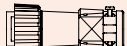

M1, M3 series

Our M1 and M3 Series connectors consist of various components which you can order individually, thus assembling a connector that suits your application to a T.

Our "Overview" on pages 4 and 5 will help you with the details of the assembly. The following table is a summary

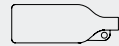







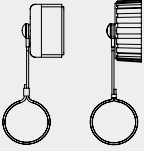
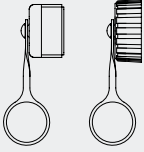

of all available individual components of our M1 and M3 Series connectors.

Please note that according to our price list minimum order quantities apply. For orders below that minimum our distributors will be at your service.

| Item | Depiction | Ordering code | | Brief Description | |
|--|---|--|--|--|--|
| | | M1 | M3 | | |
| Shell part 1 (Receptacles) |  | M11 Z M11 ZB | M31 Z M31 ZB | Cable receptacle with strain relief ZB: All components loosely packed as kit | |
| |  | M11 | --- | Cable receptacle | |
| |  | M12 M20B | M32 M25B | Cable receptacle M1: Kit comprising receptacle M14 M20 and backshell M1 M20D M3: Kit comprising receptacle M34 M25 and backshell M3 M25D | |
| |  | M13 | M33 | Flange mount receptacle | |
| |  | --- | M33 W | Receptacle for shrink boot | |
| |  | M14 Pg13.5 M14 M20 | M34 Pg21 M34 M30 | Receptacle with accessory threads | |
| |  | M18 | M38 | Flange mount angled receptacle | |
| Shell part 1 (Plugs) |  | M16 Z M16 ZB | M36 Z M36 ZB | Plug with strain relief ZB: All components loosely packed as kit | |
| |  | M16 | --- | Plug | |
| |  | M16 W | M36 W | Plug for threaded backshell and gland-seal cable clamp or 90° shrink boot | |
| |  | M16 M20B | --- | Plug kit comprising receptacle M16 W and backshell M1 M20 | |
| |  | M15 | M35 | Flange plug | |
| Shell part 2 (Backfittings and cable support sleeves/ seal rings) |  | 202K142-15 | 202K163-15 | Shrink boot straight | |
| |  | 222K142-15 | 222K163-15 | Shrink boot 90° | |
| |  | M1 Pg13.5 M1 M20 | M3 Pg16 M3 Pg21 M3 M25 | Threaded backshell for plugs with O-Ring | |
| | | M1 M20D | M3 M25D | Threaded backshell for receptacle with O-Ring | |
| |  | M1 VPg13.5 10-12 | M3 VPg16 12-14 M3 VPg21 14-18 | Gland-seal cable clamp for threaded backshell | |
| | | M1 VM20 8-13 | M3 VM25 11-17 | | |
| |  | T1-4/6 T1-6/8 T1-8/10 T1-10/12 T1-12/13 T1-14.5 | T28-10/13 T28-13/16 T28-16/18.5 T28-18.5/20.5 T28-20.5/22 --- | Cable diameter | T1 (M1) 4 ... 6 mm 6 ... 8 mm 8 ... 10 mm 10 ... 12 mm 12 ... 13 mm 14 ... 15 mm |

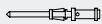
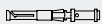
(to be continued on page 23)

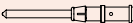
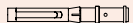
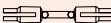
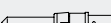
(Continued from page 22)

| Item | Depiction | Ordering code | | Brief Description | |
|-----------------|---|--|--|--|---|
| | | M1 | M3 | | |
| Protection cap |  | M1 KS M1 DS | M3 KS M3 DS | Protection cap with cord for plugs Protection cap with cord for receptacles | |
| |  | M1 K M1 D | M3 K M3 D | Protection cap with plastic strap for plugs Protection cap with plastic strap for receptacles | |
| |  | M1 K15 | M3 K15 | Protection cap with plastic strap for plugs | |
| Inserts |  | M1 E-4P+PE M1 E-4S+PE | --- --- | 4 pole + PE pin insert 4 pole + PE socket insert | |
| |  | M1 E-6P+PE M1 E-6S+PE | M3 E-6P+PE M3 E-6S+PE | 6 pole + PE pin insert 6 pole + PE socket insert | |
| |  | --- --- | M3 E-8P+PE M3 E-8S+PE | 8 pole + PE pin insert 8 pole + PE socket insert | |
| |  | --- --- | M3 E-12P+PE M3 E-12S+PE | 12 pole + PE pin insert 12 pole + PE socket insert | |
| Contacts Type A |  | SAC-0.50-Ag SAC-1.00-Ag SAC-1.50-Ag SAC-2.50-Ag | SAC-0.50-Ag SAC-1.00-Ag SAC-1.50-Ag SAC-2.50-Ag | Wire gauge*: | 0.50 mm ² 0.75 ... 1.00 mm ² 1.50 mm ² 2.50 mm ² |
| |  | BAC-0.50-Ag BAC-1.00-Ag BAC-1.50-Ag BAC-2.50-Ag | BAC-0.50-Ag BAC-1.00-Ag BAC-1.50-Ag BAC-2.50-Ag | Wire gauge*: | 0.50 mm ² 0.75 ... 1.00 mm ² 1.50 mm ² 2.50 mm ² |
| |  | BS-A | BS-A | Filler plug to fill unused contact cavities | |
| Contacts Type B |  | --- --- --- --- --- --- | SBC-0.50-Ag SBC-1.00-Ag SBC-1.50-Ag SBC-2.50-Ag SBC-4.00-Ag SBC-6.00-Ag | Wire gauge*: | 0.50 mm ² 0.75 - 1.00 mm ² 1.50 mm ² 2.50 mm ² 4.00 mm ² 6.00 mm ² |
| |  | --- --- --- --- --- | BBC-0.50-Ag BBC-1.00-Ag BBC-1.50-Ag BBC-2.50-Ag BBC-4.00-Ag BBC-6.00-Ag | Wire gauge*: | 0.50 mm ² 0.75 - 1.00 mm ² 1.50 mm ² 2.50 mm ² 4.00 mm ² 6.00 mm ² |
| |  | --- | BS-B | Filler plug to fill unused contact cavities | |
| Contacts Type C |  | --- --- --- | SCC-2.50-Ag SCC-4.00-Ag SCC-6.00-Ag | Wire gauge*: | 2.50 mm ² 4.00 mm ² 6.00 mm ² |
| |  | --- --- --- | BCC-2.50-Ag BCC-4.00-Ag BCC-6.00-Ag | Wire gauge*: | 2.50 mm ² 4.00 mm ² 6.00 mm ² |
| |  | --- | BS-C | Filler plug to fill unused contact cavities | |

The default contact finish for pin and socket contacts is silver.
For gold plated contacts change 'Ag' to 'Au' in the ordering code.

* For AWG sizes refer to the conversion table on our homepage

Schaltbau GmbH

For detailed information on our products and services visit our website – or give us a call!

Schaltbau GmbH
Hollerithstrasse 5
81829 Munich
Germany



Phone +49 89 9 30 05-0
Fax +49 89 9 30 05-350
Internet www.schaltbau-gmbh.com
e-Mail contact@schaltbau.de

with compliments:



Schaltbau GmbH manufactures in compliance with RoHS.



The production facilities of Schaltbau GmbH have been IRIS certified since 2008.



Certified to DIN EN ISO 14001 since 2002. For the most recent certificate visit our website.



Certified to DIN EN ISO 9001 since 1994. For the most recent certificate visit our website.

Electrical Components and Systems for Railway Engineering and Industrial Applications

Connectors

- Connectors manufactured to industry standards
- Connectors to suit the special requirements of communications engineering (MIL connectors)
- Charging connectors for battery-powered machines and systems
- Connectors for railway engineering, including UIC connectors
- Special connectors to suit customer requirements

Snap-action switches

- Snap-action switches with positive opening operation
- Snap-action switches with self-cleaning contacts
- Enabling switches
- Special switches to suit customer requirements

Contactors

- Single and multi-pole DC contactors
- High-voltage AC/DC contactors
- Contactors for battery powered vehicles and power supplies
- Contactors for railway applications
- Terminal bolts and fuse holders
- DC emergency disconnect switches
- Special contactors to suit customer requirements

Electrics for rolling stock

- Equipment for driver's cab
- Equipment for passenger use
- High-voltage switchgear
- High-voltage heaters
- High-voltage roof equipment
- Equipment for electric brakes
- Design and engineering of train electrics to customer requirements

We reserve the right to make technical alterations without prior notice.

For updated product information visit www.schaltbau-gmbh.com.

Issued 12-2013